



**ΑΝΟΙΚΤΟ  
ΠΑΝΕΠΙΣΤΗΜΙΟ  
ΚΥΠΡΟΥ**

**ΣΧΟΛΗ ΘΕΤΙΚΩΝ ΚΑΙ  
ΕΦΑΡΜΟΣΜΕΝΩΝ ΕΠΙΣΤΗΜΩΝ**  
ΜΕΤΑΠΤΥΧΙΑΚΟ ΠΡΟΓΡΑΜΜΑ ΣΠΟΥΔΩΝ  
«Πληροφορικά και Επικοινωνιακά Συστήματα»

## **ΔΙΑΤΡΙΒΗ ΕΠΙΠΕΔΟΥ ΜΑΣΤΕΡ**

**Evaluation of open source medical imaging  
systems and assessment of multiple sclerosis MRI  
imaging**

ΙΩΑΝΝΗΣ ΠΕΤΡΙΔΗΣ

ΕΠΙΒΛΕΠΩΝ ΚΑΘΗΓΗΤΗΣ  
ΑΝΤΡΕΑΣ ΠΑΝΑΓΙΔΗΣ

ΛΕΥΚΩΣΙΑ, ΙΟΥΝΙΟΣ, 2019



# **Evaluation of open source medical imaging systems and assessment of multiple sclerosis MRI imaging**

Thesis Report

I. Petridis

June 10, 2019

Master of Science in Information and Communication Systems Faculty of Pure and Applied Sciences Open University of Cyprus



Copyright©  
All rights reserved.



---

# Abstract

Multiple sclerosis (MS) is an autoimmune neurological disease which causes affects the myelinated axons of the central nervous system (CNS). Its characteristic is the formation for demyelinated plaques in white matter of the CNS. The disease progresses from reversible neurological deficits to permanent neurological deterioration. MS affects commonly young individuals, between 20 to 50, mostly men and imposes considerable burden for patients, presented in childhood or late middle age. Patients' daily routine and activities are diminished since almost half of them need assistance with their basic needs, like walking, as the disease progresses over time making thus MS a vital problem to handle. Some of the symptoms include numbness, weakness, loss of balance and their diagnosis should be made by experienced physicians. The diagnosis is done by clinical findings and can be supported by further auxiliary tests, like magnetic resonance imaging (MRI).

Diagnosis is one of the steps to treat MS. Early prediction of the disease's course is another. To do so, medical imaging techniques like MRI are obtained from the patients in order to estimate the symptoms' path. To be able to accurately predict the progress of the disorder, large amount of data should be acquired and analysed, knowledge should be shared across research teams and collaboration should be promoted. In doing so, scientific workflow management systems (SWMS) in life sciences are used. Those systems utilize technological advancements promoting use of distributed resources as well as data integration, such as shared access to common data sources.

Three frameworks were chosen, *MeVisLab*, *KNIME* and *Loni Pipeline*, to be evaluated as open source medical neuroimaging systems with workflow management features. One of them, *Loni Pipeline*, presented several connectivity issues which has not been solved until recently. Therefore, it was discarded from the study. The rest were examined and evaluated in terms of image registration and image segmentation, 3D-volume reconstruction, lesion visualization and lesion measuring. The two remaining systems were compared against 3D-slicer, a software tailored to medical imaging research.

---

# Contents

<b>Abstract</b>	<b>i</b>
<b>Acknowledgements</b>	<b>vi</b>
<b>1 Introduction</b>	<b>1</b>
1-1 Problem Statement . . . . .	2
1-2 Study Goal . . . . .	2
1-3 Search Approach . . . . .	3
<b>2 Theoretical Background</b>	<b>5</b>
2-1 Multiple Sclerosis (MS) . . . . .	5
2-2 Magnetic Resonance Imaging (MRI) in Multiple Sclerosis (MS) . . . . .	7
2-3 Scientific Workflow Management Systems (SWMS) . . . . .	8
2-3-1 Loni Pipeline . . . . .	9
2-3-2 MeVisLab . . . . .	11
2-3-3 KNIME . . . . .	12
<b>3 (MR)Image Processing</b>	<b>15</b>
3-1 (MR)Image Segmentation . . . . .	15
3-2 (MR)Image Registration . . . . .	16
<b>4 MeVisLab Workflows</b>	<b>18</b>
4-1 Workflow for 2D-image representation . . . . .	18
4-2 2D-Scenario . . . . .	20
4-3 Workflow for 3D-volume reconstruction . . . . .	21
4-4 3D-Scenario . . . . .	22

---

<b>5</b>	<b>KNIME Workflows</b>	<b>24</b>
5-1	Nodes' Description .....	24
5-2	Workflow for image registration .....	25
5-3	Workflow for image segmentation .....	27
<b>6</b>	<b>MeVisLab-KNIME comparison criteria and an introduction to 3D-Slicer</b>	<b>29</b>
6-1	Overview of MeVisLab and KNIME .....	29
6-2	3D-Slicer .....	31
<b>7</b>	<b>Discussion-Conclusions</b>	<b>35</b>
7-1	Discussion .....	35
7-2	Conclusions .....	36

---

# List of Figures

1-1 MS lesions axial plane .....	1
1-2 MS lesions sagittal plane .....	1
1-3 Search Strategy .....	3
2-1 Dissemination in space .....	8
2-2 Pipeline Architecture .....	10
2-3 Loni Pipeline Neuroimaging Workflow .....	11
2-4 MeVisLab Workflow .....	12
2-5 KNIME platform .....	13
3-1 MRI image elements .....	16
3-2 Multi-view MRI .....	17
3-3 Multi-temporal MRI .....	17
3-4 Multi-modal .....	17
4-1 2D-timestamps .....	19
4-2 2D-Overlay-Scenes .....	19
4-3 Patient1 - 2D-lesion-slice .....	20
4-4 Patient1 - 2D-lesion-slice .....	20
4-5 Patient3 - 2D-lesion-slice .....	21
4-6 3D-timestamps .....	22
4-7 Patient1 - 3D-Volume .....	22
4-8 Patient1 - 3D-Volume with lesions .....	23
4-9 Patient2 - 3D-Volume with lesions .....	23
5-1 Registration Workflow for 2 time-points .....	25
5-2 Registration Workflow for 3 time-points .....	26
5-3 MRI slices - 2 time-points .....	26



---

5-4 MRI slices - 3 time-points .....	27
5-5 Segmentation workflow .....	27
5-6 MRI segmentation at 1 <sup>st</sup> time-point .....	28
5-7 MRI segmentation at 2 <sup>nd</sup> time-point .....	28
6-1 3D-Slicer-Views .....	31
6-2 3D-Slicer-Volume Reconstruction .....	31
6-3 3D-Slicer-Lesion1 .....	32
6-4 3D-Slicer-Lesion2 .....	32
6-5 3D-Slicer-Lesion-Measurements .....	33

---

# Acknowledgements

I would like to thank everyone who helped me with the writing of this thesis report.

I would first like to thank the experts who were involved in the thesis Constantino Pattichi and Christo Loizou, professors at University of Cyprus and members at electronic health (eHealth) lab and Andreas Panayides, research collaborator at electronic health (eHealth) lab. Without their passionate participation and valuable comments, the thesis report would not have been successfully conducted.

Finally, I must express my very profound gratitude to my partner and family for providing me with unfailing support and continuous encouragement throughout my studies and through the process of researching and writing this report. This accomplishment would not have been possible without them.

“The future of technology – and medicine in general – is not in blood and guts  
but in bits and bytes.”  
— *Richard Satava*

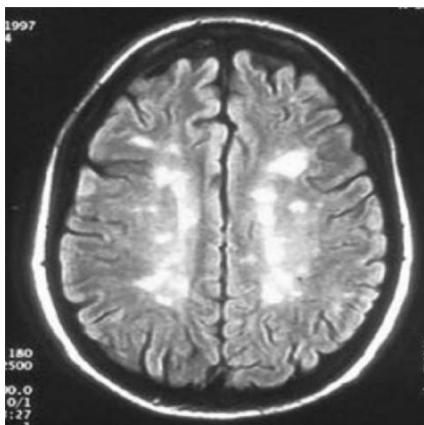
---

# Chapter 1

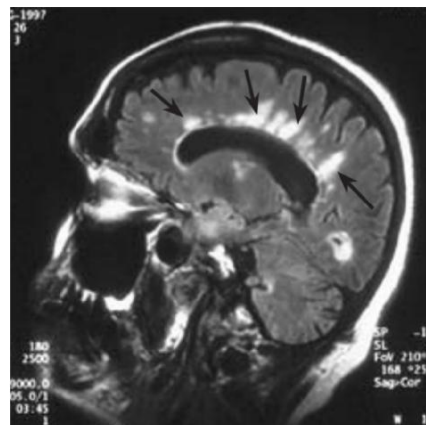
---

## Introduction

Multiple sclerosis (MS) is an autoimmune neurological disease which causes recurrent immune attacks of different degrees and it affects the myelinated axons of the central nervous system (CNS). Its dominant characteristic is the formation of demyelinated plaques in white matter of the CNS [1] as depicted in figures 1-1 and 1-2. Despite the fact that its course tends to be highly unpredictable, the disease progresses from reversible neurological deficits to permanent neurological deterioration, capturing by the shape, distribution, morphology and evolution of the lesions. Extended research has been done, but the prediction of MS progress is yet to be understood as there are many factors that play a crucial role to it. Some of them are believed to be genetic, environmental, metabolic and virus-related [2][3][4][5]. The problem statement, the study goal and the research approach will be discussed in this chapter.



**Figure 1-1:** Axial slice of a MS patient depicting lesions [3].



**Figure 1-2:** Sagittal slice of a MS patient depicting lesions [3].

## 1-1 Problem Statement

MS affects commonly young individuals, between 20 to 50 [2][6], triple men as women [6] and imposes considerable burden for patients. It is sometimes present in childhood or late middle age [2]. Patients' daily routine and activities are diminished since almost half of them need assistance with their basic needs, like walking, as the disease progresses over time [7][8]. The aforementioned facts make MS a vital problem to handle.

Some of the symptoms include numbness, weakness, loss of balance and their diagnosis should be made by experienced physicians [3]. The diagnosis is done by clinical findings and can be supported by further auxiliary tests, like magnetic resonance imaging (MRI) [2].

Diagnosis is one of the steps to treat MS. Early prediction of the disease's course is another. To do so, medical imaging techniques like MRI are obtained from the patients in order to estimate the symptoms' path. To be able to accurately predict the progress of the disorder, large amount of data should be acquired and analysed, knowledge should be shared across research teams and collaboration should be promoted. In doing so, scientific workflow management systems (SWMS) in life sciences are used. Those systems utilize technological advancements promoting use of distributed resources as well as data integration, such as shared access to common data sources [9].

Understanding those systems and their features is very important since they can be used as a communication channel among scientists and help them draw research conclusions really fast, conquering more scientific domains [9]. Integrating those systems among research teams globally is a future step that gains ground rapidly. Therefore, they should be further investigated in order to optimize their contribution to the scientific community that will eventually help in fast prediction and therefore treatment or avoidance of MS and other neurological disorders.

## 1-2 Study Goal

The goal of this graduation project is to identify and evaluate open source medical neuroimaging systems with workflow management features, i.e. SWMS, in combination with neurological disease's (MS) MRI images. By examining the selected scientific workflow management systems, conclusions will be made on the basis of the disease's progress. The necessity, that is also the innovation of this research lies on the fact that it is yet unknown whether open source SWMS neuroimaging software is able to be used as a tool to investigate the onset and the progress of a neurological disorder like MS.

The literature survey will focus on the application of several SWMS neuroimaging software to assess their validity, with an application in MS research. The characteristics-features of each software will be reviewed and compared. Emphasis will be given on Loni Pipeline [10], Mevislab [11] and KNIME [12]. Moreover, MRI lesions of MS will be reviewed in order to understand the disease.

The main project will focus on the creation and evaluation of the workflows aiming to assess their features. The created workflows will help in the visualization, segmentation, registration and 3D-reconstruction using MRI images.

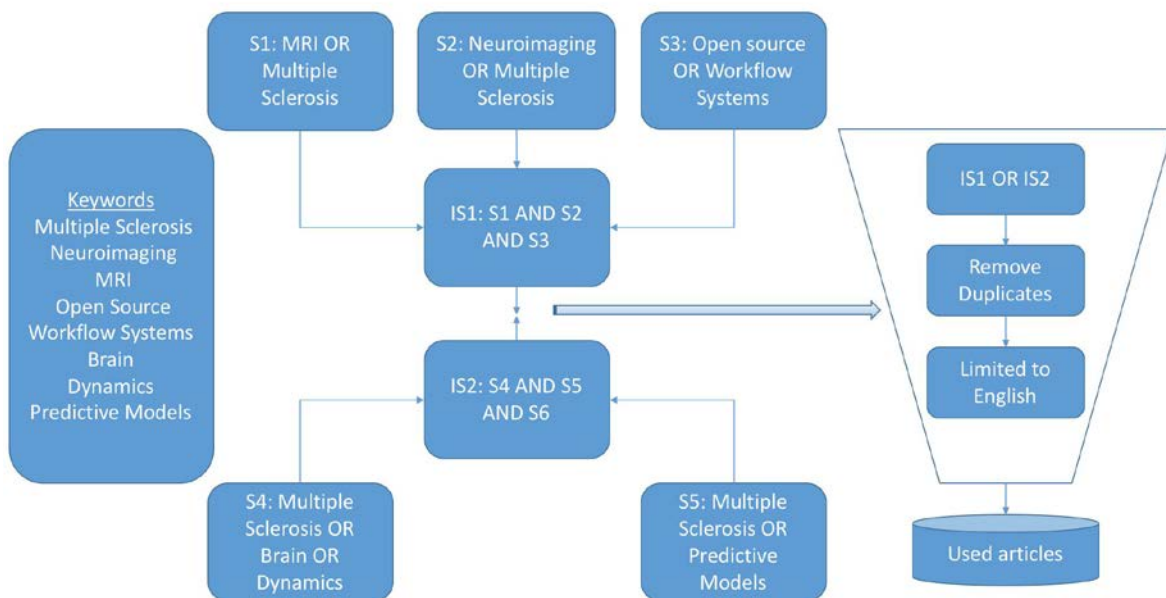
Research questions:

1. "Can workflow management systems be used for MRI segmentation, registration and 3D volume reconstruction"
2. "Is a generic workflow system able to be used as a sole tool in medical imaging research"

### 1-3 Search Approach

The approach that was used for the literature review is by using keywords in Google Scholar, Scopus, Science Direct, Pubmed, IEEE, the library of the university and other eligible article databases. Therefore, the articles that have been found come from reliable sources regarding the topic. First a list of relevant keywords was created. S1–S2 –S3 and S4–S5 correspond to the first sets of search terms. Articles containing each keyword were discovered and evaluated. The second sets of search terms, IS1 and IS2 derived from the combinations of the first sets. After collecting them, duplicates and non-english papers were removed in order to result in the final pool of articles used for this study.

Keywords: Multiple sclerosis, Neuroimaging, MRI, dynamics, open source, workflow systems.



**Figure 1-3:** Keyword combinations for article extraction.

The literature survey was based on PICO strategy, a method that allows researchers to accurately form the research question and locate the most appropriate scientific information, such as keywords for the identification of the most suitable articles. PICO strategy is the most indicative to be used in medical research as it allows the comparison between two

groups (patients and control), after intervention (diagnosis, prognosis, therapeutic, preventive, related to economy, etc.), and comparison of the results [13].

The following table presents the four components of the PICO strategy and illustrates the connection to this project:

Acronym	Definition	Description	Connection to this project
<b>P</b>	Patient/Problem	Can be a group of people with a specific condition	Patients with MS
<b>I</b>	Intervention	Represents the intervention of interest	Diagnostic using MRI images
<b>C</b>	Comparison	Comparison among interventions	Comparison of the imaging systems
<b>O</b>	Outcome	Expected results	Results explaining which imaging system is suitable for medical research

**Table 1-1:** Explanation of PICO strategy and connection to this project [13].

---

# Chapter 2

---

## Theoretical Background

In this chapter, background information about MS and MRI in MS will be given. Moreover, three open source software systems, KNIME, Loni Pipeline, MeVisLab, that can be used as SWMS will be introduced.

### 2-1 Multiple Sclerosis (MS)

MS is a neurological disorder that affected almost 2.3 million individuals in 2013. Approximately half of them are located in Europe [37][38]. Its prevalence in Cyprus is 175 per 100 thousands exceeding the average prevalence in Europe which is 106 per 100 thousands people [39][40][41]. Although MS inflicts women three times more than men, the disease does not distinct between genders and ages and therefore can be observed in children and after 60 years of age. The onset of the disease is mainly between 20-50 with a mean age of 30 years [6]. MS is listed as one of the top ten primary disabling disorders. It was classified as the 4<sup>th</sup> cause of neurological disabilities in the study of Global Burden of disease in 2013 and ranked after Alzheimer, Parkinson and Epilepsy [42].

The symptoms attributed to MS vary highly and originate in different parts of the central nervous system. They are manifested either alone or in combination forming sudden attacks or a steady progression of the disease. The most common symptoms include motor weakness and gait disturbances, dizziness and vertigo, fatigue, visual impairment, ataxia and cognitive dysfunction [6][43]. Their accumulation over time leads to disease progression resulting in walking impairment after 10 years, need for unilateral support during walking after 15-20 years and reduction of life expectancy by almost 10 years [6].

Based on the course of the symptoms, the patients, suffering from multiple sclerosis, are grouped in four major categories (stages) and six subtypes as Goldenberg (2012) and Milo (2014) respectively proposed and are outlined below [2][6][43][44][45][46]:



## Stages of multiple sclerosis

1. **Relapsing–Remitting MS (RRMS):** It is the most common form, affecting about 85% of MS patients. It is characterized by relapses or exacerbations of symptoms followed by periods of remission, when symptoms improve or disappear [2].
2. **Primary-Progressive MS (PPMS):** Affects approximately 10% to 15% of MS patients. Symptoms continue to aggravate gradually from the beginning. There are no relapses or remissions, but there may be occasional plateaus. This form of MS is more resistant to the drugs typically used to treat the disease [2][6].
3. **Secondary-Progressive MS (SPMS):** It may develop in some patients with relapsing–remitting disease. Treatment with disease-modifying agents helps delay such progression for many patients. The disease course continues to worsen with or without periods of remission or settling of symptom severity (plateaus) [2]. 50% of RRMS converts to SPMS in 10 years from the onset and 90% in 25 years [6].
4. **Progressive-Relapsing MS (PRMS):** A rare form, affecting fewer than 5% of patients. It is progressive from the start, with intermittent flare-ups of worsening symptoms along the way. There are no periods of remission [2].

## Subtypes of multiple sclerosis

1. **Clinical Isolated Syndrome (CIS):** The first episode that suggests the existence of MS [6][44].
2. **Radiologically Isolated Syndrome (RIS):** The finding, using MRI, of lesions without though the existence of evidence of clinical symptoms [6][45].
3. **Benign MS:** A concept that the patients does not present any neurological disabilities in 15 years from the onset of the disorder [6][46].
4. **Malignant MS:** Rapid progressive disease that may result in death after short time from the onset [6][46].
5. **Single attack progressive MS:** Considered to be subtype of the SPMS in which the progressive phase of the disease follows a single first attack [6][43].
6. **Transitional MS:** It's the transition phase between RRMS and SPMS. This sometimes happens gradually [6][43].

Diagnosis of the disease does not have a single laboratory test but it relies mainly on clinical tests that evaluate not only the symptoms manifestation but also the dissemination of the lesions, the central key of the disease, over time and space. The most sensitive test to depict the lesions and support the diagnosis is MRI which can be used to estimate several lesions' characteristics [6].

Many factors play crucial role in onset and progression of MS and its categories. Those can be genetic, environmental like geographic regions, metabolic and virus-related [2][3][4][5].

To understand though MS epidemiology, the aforementioned factors should be studied inter-twined and not in isolation [47].

MS is a considerable burden to patients and society. Society suffers from economical losses due to absenteeism from work and early retirement, as well as hospitalization expenses, while patients lose part of their lives as they cannot be productive and participate in their daily routine [48].

## 2-2 Magnetic Resonance Imaging (MRI) in Multiple Sclerosis (MS)

As mentioned above, MRI has been included in the diagnostic procedure of MS as a supplementing tool leading thus, together with the clinical and laboratory analysis, to the need of certain criteria that will depict the existence of MS and will distinct it from other neurological disorders. The criteria are based on the existence of disseminating lesions across the CNS. Specifically the shape, distribution, morphology and evolution of the lesions depending on MRI techniques is examined [49].

Multiple Sclerosis is characterized by dissemination of the lesions over time and space and as MRI develops further every year, the display of the lesions becomes more accurate, leading therefore to more accurate diagnostic criteria [49].

Based on the current criteria for MS, also known as the 2010 McDonald criteria [50] and the MAGNIMS' (European collaborative research network that studies MRI in MS) additional modifications [49] the MRI criteria are listed below and act complementary to the clinical and laboratory tests:

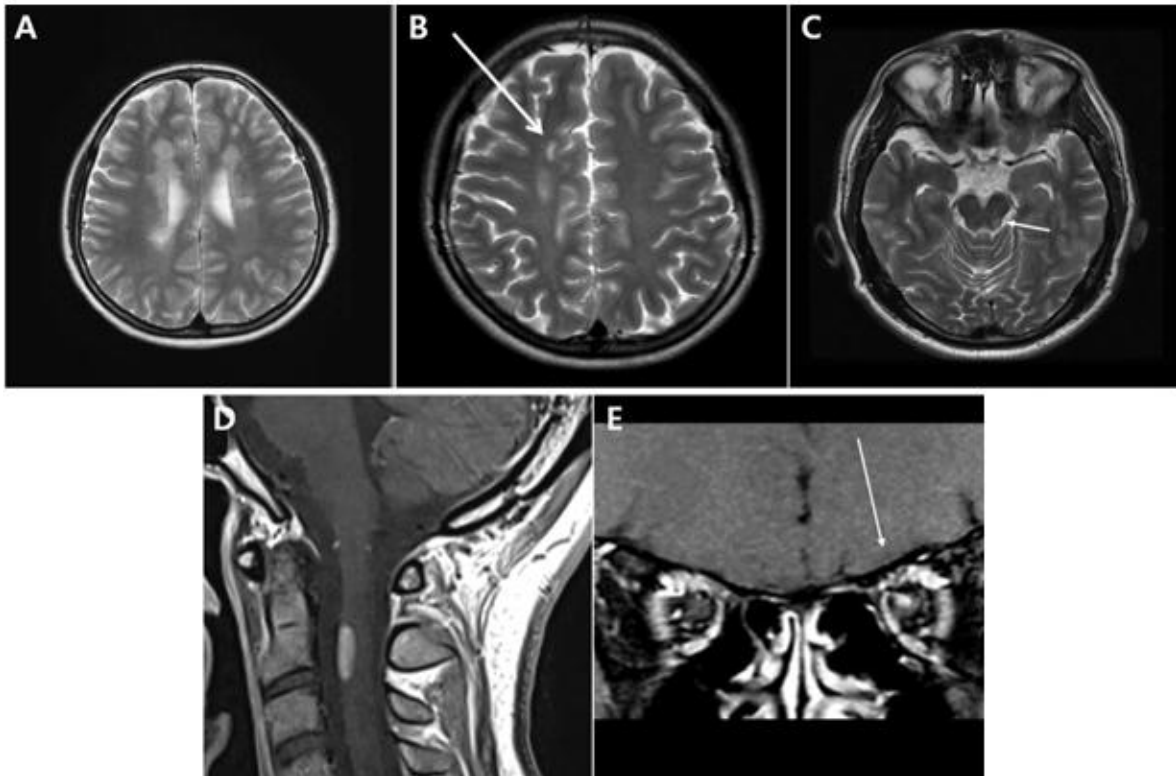
1. Dissemination of lesions in space (DIS) can be shown with the involvement at least two out of five CNS regions as described next [49][50]:
  - Three or more periventricular lesions
  - One or more infratentorial lesions
  - One or more spinal cord lesions
  - One or more optic nerve lesions
  - One or more cortical or juxtacortical lesions

An example of the aforementioned CNS areas, presenting lesions, can be seen in Fig 2-1.

2. Dissemination of lesions in time (DIT) is demonstrated by [49][50]:
  - At least one new T2<sup>1</sup> lesion on follow-up MRI, with reference to a baseline scan.
  - Simultaneous presence of asymptomatic lesions at any time.

---

<sup>1</sup>T2 refers to white spots, while T1 refers to black spots observed in MRI



**Figure 2-1:** Example of MRI imaging depicting disseminating lesions in space in multiple sclerosis. A) periventricular lesions B) juxtacortical lesions C) infratentorial lesions D) spinal cord lesions E) optic nerve lesions [51].

## 2-3 Scientific Workflow Management Systems (SWMS)

Computational neuroscience and hence MS research, depends on the gathering and analysis of large amount of heterogeneous data and their interpretation by multidisciplinary experts. A problem the scientist often face is to discover meaningful patterns in the gathered data, choose a suitable model for fitting the data and discover appropriate visualization and analysis tools for addressing the scientific challenges [52][53]. Moreover, as new technologies emerge, vast amount of clinical, imaging and behavioral data are extracted independently from several geographically dispersed research institutions [54]. Having access to this plethora of data, gives the opportunity for data exchange among researchers, accelerating the scientific discoveries [55][56]. The aforementioned facts have driven the creation of systems able to deal with the data flow and management, resources exchange, analysis, visualisation, simulation and scientists' collaboration worldwide so as *in silico* experiments to be successfully carried out [9].

SWMS are fundamental tools that automate an experiment relieving the scientists from repetitive tasks and keeping track of intermediate steps and data. They also provide pipeline parallelism incorporating separate group of threads, each handling a different task. The groups are processed at the same time providing high efficiency. Another virtue of the SWMS is visualisation tools they provide in each experimental phase for evaluation of the results [9]. Therefore, it can be seen that SWMS have features necessary for processing fast, a large

of MRI images from MS patients with accuracy and sensitivity [57].

The features that make SWMS attractive are listed below [9]:

- **User-friendliness:** Most of the SWMS are still sophisticated but steps are made towards systems with easier interface for non-experts users [9].
- **Support Mechanisms:** Since there is online access to the system, each member of scientific community can contribute easier in providing documentation, tutorials and common errors [9].
- **Error Handling:** Current systems are equipped with error checking tools. However, an effort is made to have meaningful error messages [9].
- **Integration of Heterogeneous Resources:** SWMS are able to integrate data and resources from multiple different sources. Data can be accessed and visualised through a web browser [9].
- **Inter-operability:** This type of systems should be interoperable, i.e. be platform independent and interact, for example through internet, with other systems [9].
- **Workflow Sharing:** Sharing is one of the key advantages of SWMS, providing the foundation of collaboration among scientists [9].
- **Provenance Capture:** SWMS keep track of the information flow in each stage of an experiment ensures reproducibility [9].

Loni Pipeline implemented in the University of Southern California [10], Mevislab implemented by MeVis Medical Solutions AG and the research institute Fraunhofer MEVIS [11] and KNIME software suite created by KNIME AG [12] are three open source SWMS that look promising not only for MS research, but also for other neurological disorders. The selection of these systems was based on the fact that they are free and that they are supported by scientific community. An effort to review the three software was made in order to gain a better insight of the tools.

### 2-3-1 Loni Pipeline

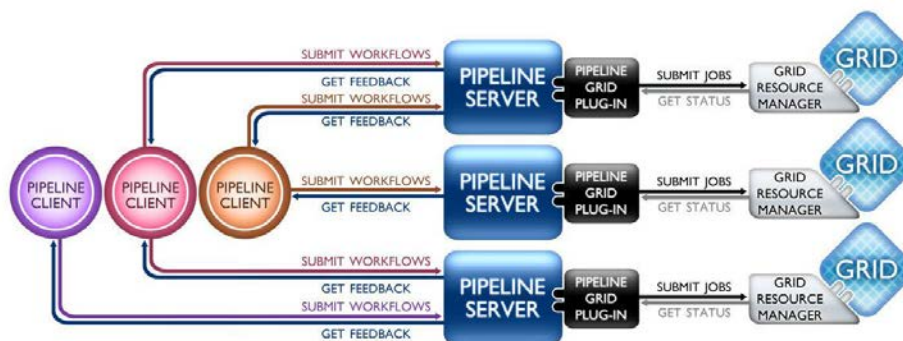
Starting with Loni Pipeline, it is a free, portable, efficient and distributed computing workflow application mainly aimed for neuroscience researchers [58][59]. It enables software inclusion from different laboratories in different environments [58], creating thus easily workflows and taking advantage of all available neuroimaging tools.

The software can link together individual executable programs or modules, into a processing tree, creating thus a pipeline that contains the information regarding connectivity between processing modules. Moreover, it allows the accurate exchange of files, results and other useful information between interconnected modules. A pipelet is a part of a pipeline that is treated as a separate module inside a pipeline [58]. The description of the modules and pipelines is implemented in Extensible Markup Language (XML) allowing any command-line processes, web-service or data-service, to be accessed within the environment by reference

and without the need of an application interface [59] and the need for all information to be embedded in the environment itself [52].

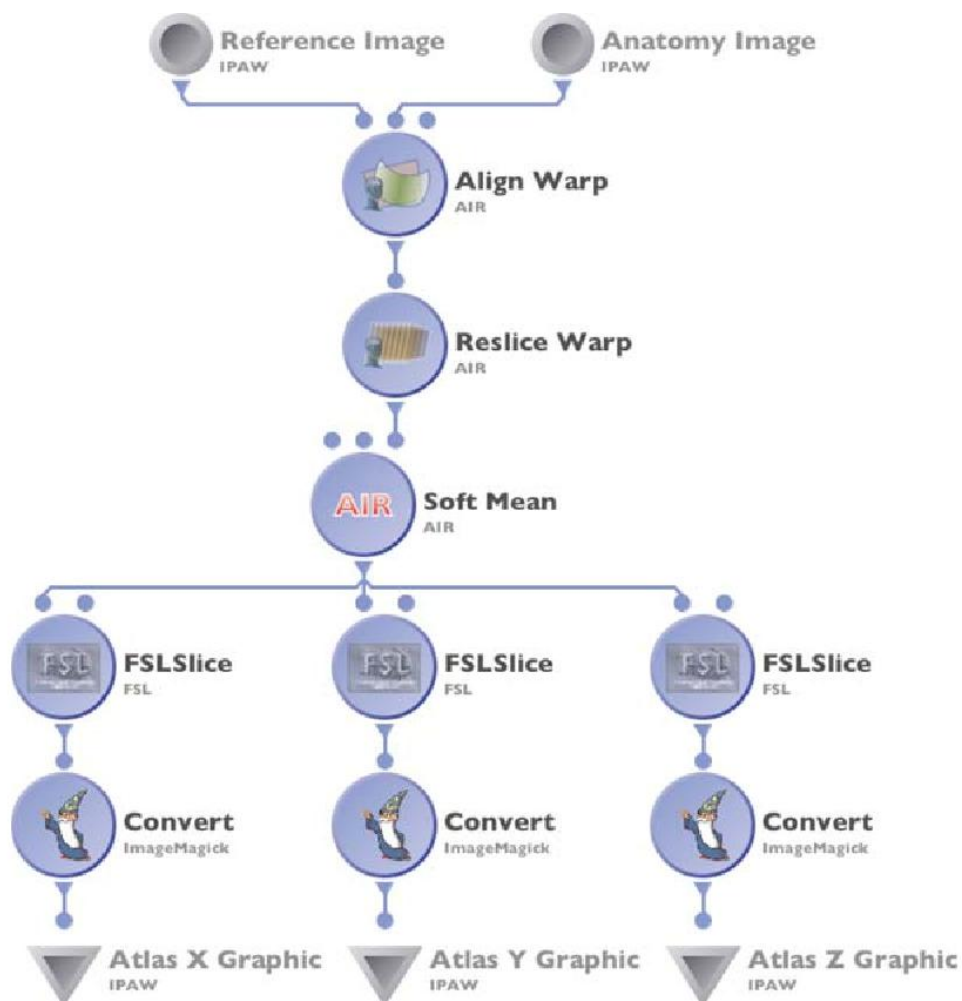
As a modular environment, i.e an environment which is not entirely encapsulated in one software package, but instead all analysis techniques, subroutines and programs are incorporated individually, provides flexibility and complete control [58]. Modularity though, may raise interoperability issues between different steps and difficulties in choosing the suitable package, subroutine or analysis techniques [58].

Another advantage of Loni Pipeline is that it is parallel process efficient. It uses data-flow model which is based on a directed graph, to ensure its parallel architecture. Processing functions, or modules, are represented by nodes and data pipes are represented by edges depicting the flow of data between the functions. All modules that are data independent on each other can be parallel executed [58]. To make sure that the data-flow model does not exceed available computing power there is a first-in–first-out, or FIFO, launch queue. Moreover, the software has access to LONI's supercomputer cluster allowing grid utilization of the client server infrastructure [52][58] providing therefore broad resource distribution [59]. A schematic of pipeline clients connected to pipeline servers which support grid computing is depicted in Fig 2-2 while a simple neuroimaging workflow using Loni pipeline is illustrated in Fig 2-3.



**Figure 2-2:** Schematic representation of pipeline clients connected to pipeline servers supporting remote grid computing [60].

One of the biggest issues of such interconnection between clients and servers is security. The Loni Pipeline environment has integrated authentication protocols that offers maximum agility of diverse policies governing system authentication and access control. The pipeline server implements encrypted passwords for account access, while the client has restricted rights regarding the files and their transfer from the server [52][58][59][60].



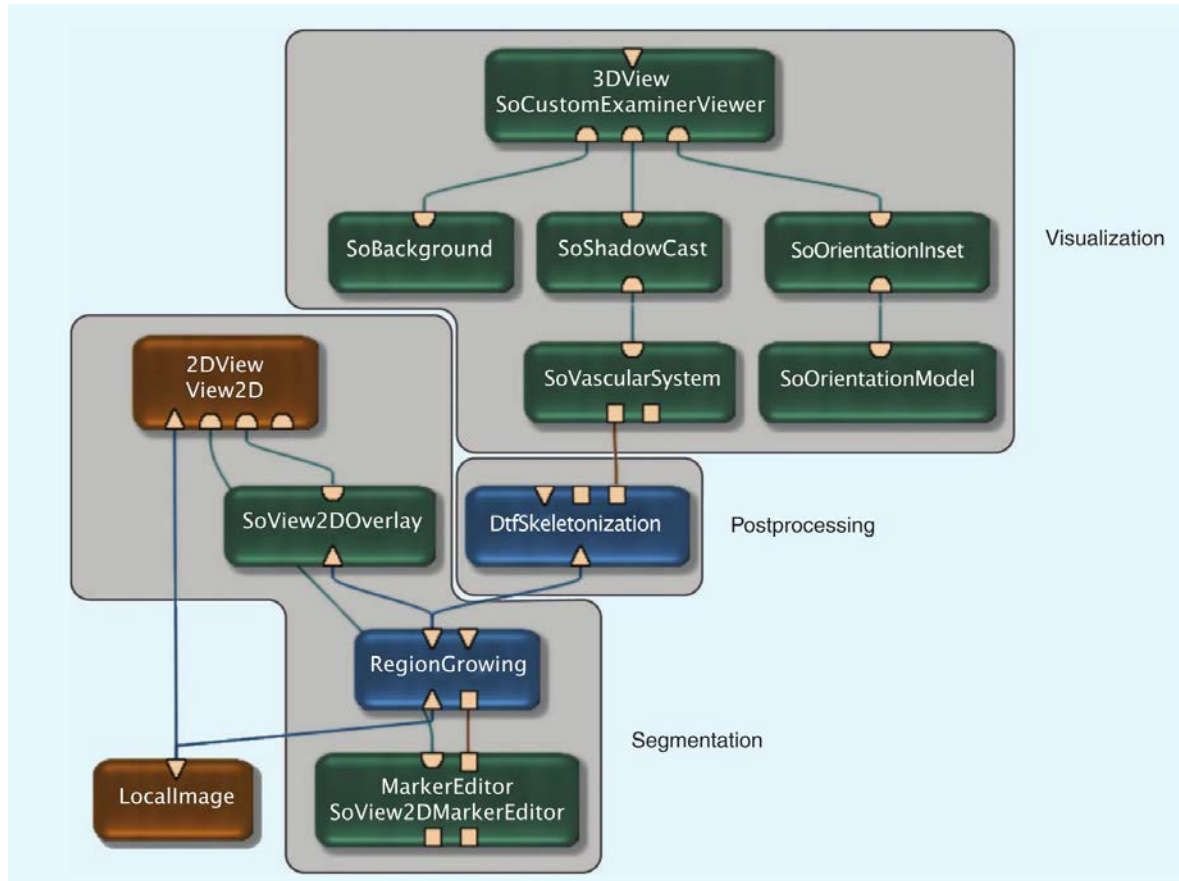
**Figure 2-3:** Simple Neuroimaging Workflow using the Loni Pipeline. The small circles, related to reference (label) and anatomy (label) images, represent the source of the data, the large circles represent the different modules, the edges represent the data flow and the triangles represent the output [61].

### 2-3-2 MeVisLab

Continuing with MeVisLab, it is a graphical data-flow programming framework, open source [62][63] and cross platform compatible, consisting of image processing and visualization tools [64]. In the software package two toolkits are included, the Insight Segmentation and Registration Toolkit (ITK) and the Visualization Toolkit (VTK) [64]. The two toolkits are basically libraries responsible for handling heavy computation burden [63].

Modularity is one of the MeVisLab's advantages, since the environment provides medical image processing (colored in blue) and visualization (colored in green) blocks or modules that can be combined with a graphical visual approach, leading thus to the creation of new module networks (e.g algorithms) that implement certain functionalities [62]. Moreover, macro modules (colored in brown) [65], i.e a higherlevel modules that encapsulate lower level multiple modules, can also be created forming thus a more complex module network also called a

scene graph or a pipeline [62]. A scene graph is depicted in Fig 2-4, where an image is loaded, segmented, post-processed and visualized using the respective modules.



**Figure 2-4:** A modular MeVisLab network consisting of three subnetworks implementing visu-alization, post-processing and segmentation. Each subnetwork consists of image processing and visualization blocks/modules colored respectively in blue and green. Macro modules colored in brown are also exist [62].

Lastly, MeVisLab uses an abstract module definition language (MDL) offering the ability to create graphical user interfaces for an application. Moreover, using *Python* and *JavaScript*, dynamic functionality can be added to an application. Finally, *C++* code can be used for integration with the macro modules [63][64].

### 2-3-3 KNIME

KNIME (Konstanz Information Miner) is another promising imaging-based and open source tool SWMS that enables visual assembly and interactive execution of data pipelines [66]. KNIME was initially developed for pharmaceutical research. Later, its usage expanded to financial analysis, business intelligence, retail, manufacturing, government research and life sciences [12]. A typical example of KNIME software can be seen in Fig 2-5. The figure presents an illustration of the user interface. At the left, the file and node browsers can be seen, at the middle the palette, where the workflows are created is demonstrated, and at the

right, the node description is depicted followed by the console which is used for alerting the user about warnings and errors occurred during the execution.

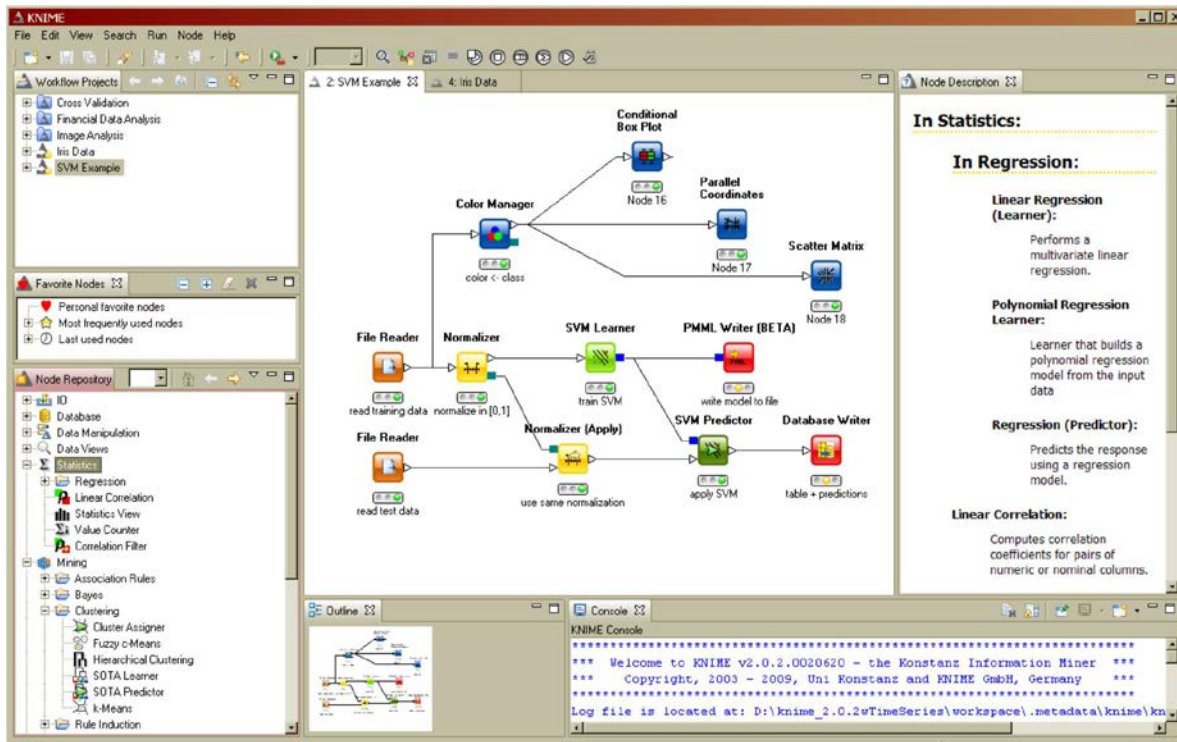


Figure 2-5: Typical example of KNIME platform [66].

The KNIME suite has been designed taking into consideration three principles [66].

1. **Visually interactive framework:** Drag and drop can be used to combine processing units like nodes or workflow pipelines. Nodes follow the Model-View-Controller architecture and correspond to the simplest processing unit. Workflow pipelines constitute complex structures consisting of multiple nodes [66].
2. **Modularity:** Data processing units are independent on each other and can be combined to create complex projects in a single pipeline [9][66].
3. **Easy extensibility:** Newly developed processing units can be added simply, by plugin mechanisms without the need of complicated install/uninstall procedures [66].




The aforementioned design principles lead to the one of the biggest advantages of KNIME. In contrast to many other workflow systems, KNIME has the ability to stop, review, edit and resume the procedure at any step of the pipeline, importing or exporting data, deleting or adding nodes without the need to re-execute the previously executed processing units [66].

KNIME supports predictive model markup language (PMML) which is an XML-based open standard for creating, storing and exchanging predictive and regression models in XML format [66]. KNIME platform, although written in Java, allows the running of scripting nodes.



Most of these nodes are implemented in Python and Perl. It also supports JDBC, a java-based access technology that provides methods for querying and updating data in a database [66]. Lastly, another significant advantage of KNIME that derives from its modularity, is the ability to distribute designated nodes to separate processors and hence execute in parallel.

To conclude a comparison table with key characteristics of each software management workflow system is given below:

Characteristics	Loni Pipeline	MeVisLab	KNIME
Initially Designed For	Neuroscience Research	Medical Image Processing Research	Pharmaceutical Research
Workflow Environment	✓	✓	✓
Parallel Processing	✓	✓	✓
Cross Platform Compatibility			
Modularity	✓	✓	✓
Client - Server Model	✓	✗	✓
Grid Computing	✓	✗	✓
Resources Collection	✓	✓	✓
Availability	Free	Free with restrictions	Free with restrictions

**Table 2-1:** Comparison table of Loni Pipeline, MeVisLab and KNIME illustrating the key features of each system.

---

## Chapter 3

---

# (MR)Image Processing

This chapter will introduce the steps that are being done in order to evaluate MRI images to conclude about the dynamics of a possible disorder. Specific information about MRI segmentation and MRI registration in different time stamps will be provided.

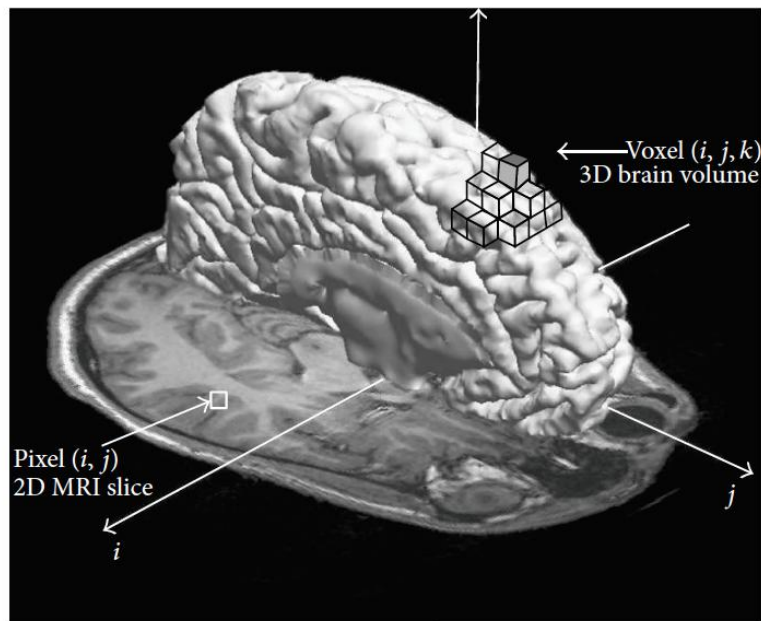
### 3-1 (MR)Image Segmentation

MRI segmentation of the brain is an important task for the analysis of the MRI since it influences the outcome of many clinical applications such as analyzing brain development, visualizing brain structures and image-guiding planning interventions for surgery. During segmentation the image is divided into sets of semantically meaningful, non-overlapping and homogeneous regions of similar attributes such as intensity, depth, color, or texture describing either region boundaries or identifying homogeneous regions like white matter (WM), gray matter (GM) and cerebrospinal fluid (CSF) [67].

Image segmentation can be performed in 2D or in 3D space. 2D and 3D images are defined respectively as functions of  $I(i, j)$  and  $I(i, j, k)$  where  $i = 0, 1, \dots, M - 1$ ,  $j = 0, 1, \dots, N - 1$  and  $k = 0, 1, \dots, D - 1$  denote spatial coordinates and every image consists of finite elements called pixels in 2D space and voxels in 3D space as depicted in Fig 3-1 [67].

There are plenty of methods able to perform MRI segmentation and some of them are presented here below:

- **Manual segmentation:** It refers to a process where a human operator (e.g. a physician) segments an image manually. For 3D volumetric images the segmentations is done in a “slice-by-slice” manner [67].
- **Intensity-based methods:** It refers to classification of the individual pixels and voxels based on their intensity [67].



**Figure 3-1:** Representation of a pixel in 2D slice and a voxel in 3D space [67] for a 3D MR brainimage.

- **Atlas-based methods:** It is a powerful tool for segmentation because it is based on the existence of an atlas or template of the human brain for a specific population. The atlas contains prior knowledge about the anatomy of the brain and it is used as reference [67].
- **Surface-based methods:** Its an addition to intensity-based and atlas-based methods. It refers to a number of alternative brain MRI segmentation approaches that include deformable models, active contours and surfaces [67][68][69][70][71].
- **Hybrid segmentation methods:** It is a combination of several techniques that help in solving emerging MRI segmentation problems. The idea is to combine different complementary methods into one hybrid approach to improve segmentation accuracy as much as possible [67][72][73][74].

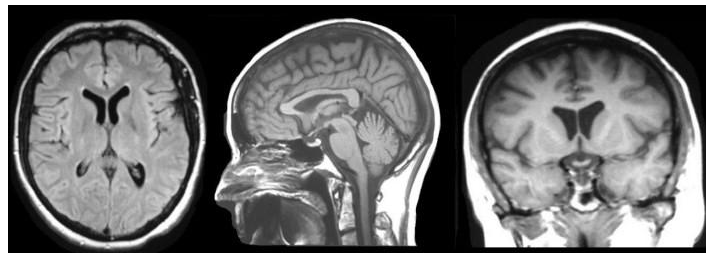
MRI segmentation is a crucial procedure that can define the outcome of the analysis and it is up to users to select the most suitable method. However before segment the image several preprocessing steps need to be done in order to prepare the MR image for segmentation. For the current study manual segmentation was used. One of the most important steps is image registration [67].

### 3-2 (MR)Image Registration

(MR)Image registration is the process during which two or more images of the same person overlay. It involves the discovery of transformation among images in which the examined features are spatially aligned. The images are taken at different times, from different scanning

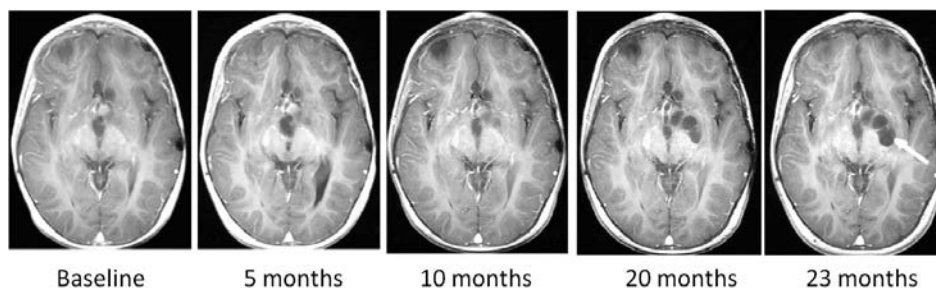
angles, equipment and sensors, presenting therefore differences. The purpose of image registration in medical imaging analysis is to acquire more complete information about patient's health in different time points (i.e before and after applying treatment) [67][75]. Based on the way of image acquisition, image registration process can be divided into three groups as follows:

- **Multi-view analysis:** Images of the same scene acquired from different points-angles, aiming to gain larger 2D or 3D representation [76] as depicted in Fig 3-2.



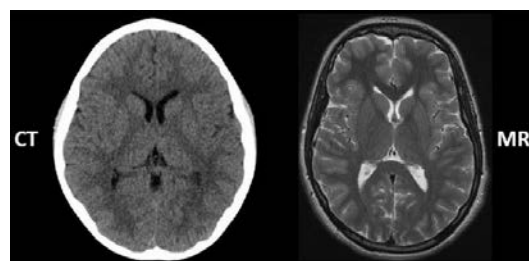
**Figure 3-2:** Presentation of a multi-view brain MRI.

- **Multi-temporal analysis:** Fig 3-3 illustrates the representation of images of the same scene acquired at different times and possibly under different conditions. This type of analysis takes place often in a regular basis, aiming to discover differences between consecutive images [76].



**Figure 3-3:** Representation of a multi-temporal brain MRI.

- **Multi-modal analysis:** Images of the same scene are acquired using different techniques, e.g. MRI, PET, CT as it is demonstrated in Fig 3-4. The aim is to gain more complex information about the scanned object [76].



**Figure 3-4:** Presentation of a multi-modal brain image.

---

## Chapter 4

---

# MeVisLab Workflows

In this chapter some MeVisLab scenarios will be presented. The scenarios refer to MS patients. MRI registration in certain time stamps will be depicted and lesions progress will be observed through these scenarios. Before presenting the scenarios, information about the used workflows and modules will be provided.

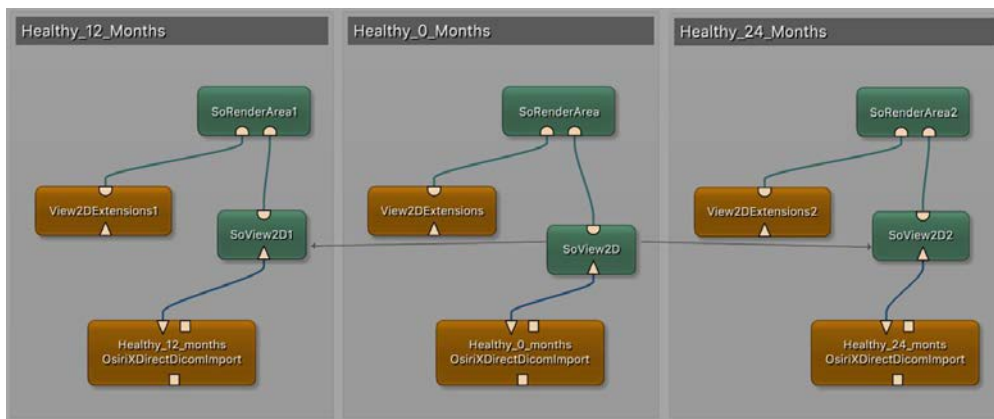
### 4-1 Workflow for 2D-image representation

Modules that were used for the design of the 2-D MeVisLab workflows are outlined here below:

- **View2DExtensions:** View2DExtensions module encapsulates a set of viewer extensions (navigation, level/window adjustment and drawing annotations) that are commonly used in conjunction with a 2D viewer [11].
- **OsiriXDirectDicomImport:** This module can be used for importing DICOM and othertype of image files. Two of those modules were used. One for each MRI slice and one for rendering the lesions for each slice [11].
- **ImagePropertyConvert:** Usually the images' properties are not the same since they can be taken from different equipment. In order to be able to merge two images, they should be converted according to a same reference point [11].
- **ColorModelConvert:** ColorModelConvert module is used in order to change the color of the depicted images, making the results more visible, according to users' preference [11].
- **SoView2D - SoView2DOverlay:** SoModules are modules responsible for visualizing the images. In this study a SoView2D module is used in order to visualize the brain lesions. Another SoView2D module can be used in case of visualizing the MRI slices separately. In our case a SoView2DOverlay module is used for holding the information about overlaying the MRI lesions on the MRI slices. This information will be then sent to SoRenderArea module for visualization [11].

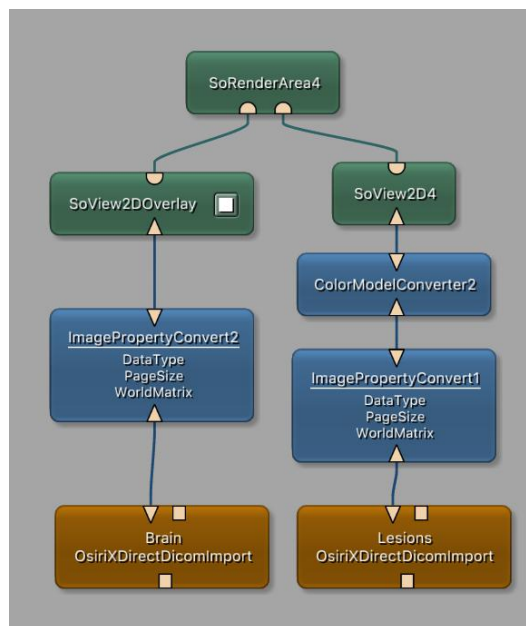
- **SoRenderArea:** The SoRenderArea module is used in order to present two different scenes (e.g. MRI of a slice and lesions) at the same view. SoView2DOverlay and SoView2D modules, depicting the MRI slice and the lesions respectively, pass the information of their scenes to the SoRenderArea module [11].

For registering 2-dimensional MRI images in different time points the workflow depicting in Fig 4-1 was used. As it can be seen, the same sub-workflow is used for each time point. The connections between the SoView2D modules help in interchanging MRI slices, i.e every time the user change the slice at the first time point, the slices of the other time stamps change automatically.



**Figure 4-1:** Workflow for presenting MRI slices at different time stamps (0, 12 and 24 months).

For rendering 2-D MRI slices together with the MRI lesions the workflow depicted in Fig 4-2 was used.



**Figure 4-2:** Workflow for representing MRI slices and lesions.

### 4-2 2D-Scenario

MRI scans from patients with MS were recorded at different time points in order to visually check the progress of the disorder through time. MeVisLab software gives us the ability to depict each MRI slice in all corresponding time points simultaneously allowing thus the visual inspection and comparison of the MRI slices. Fig 4-3 - Fig 4-5 represent a randomly selected slice for three different cases, including the lesions, for two different time points.

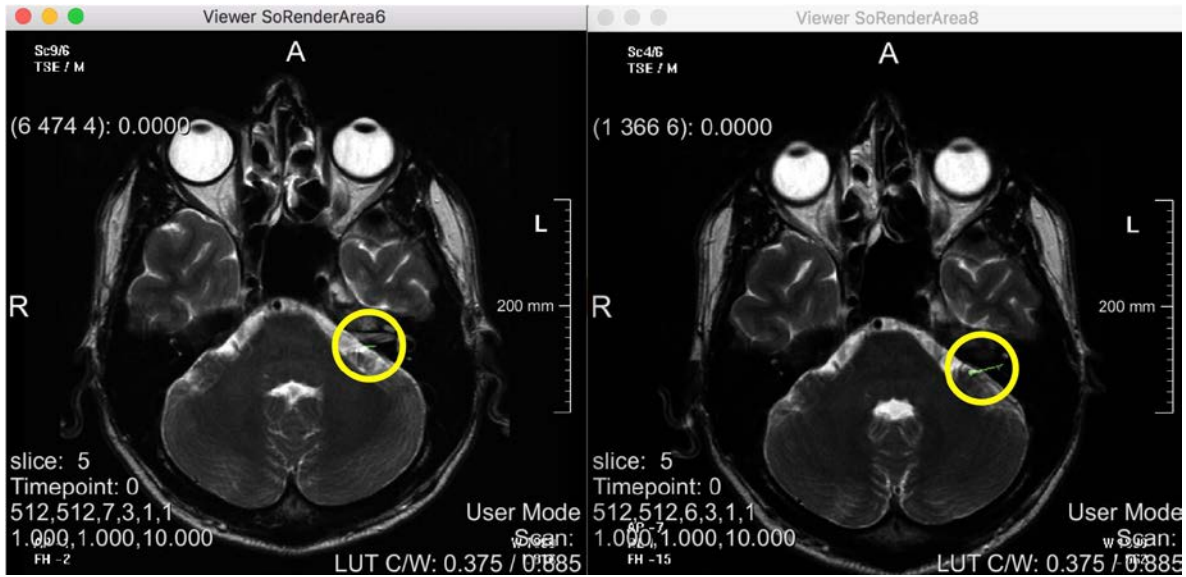


Figure 4-3: Patient1 - 2D slice in different time points (0 and 6 months).

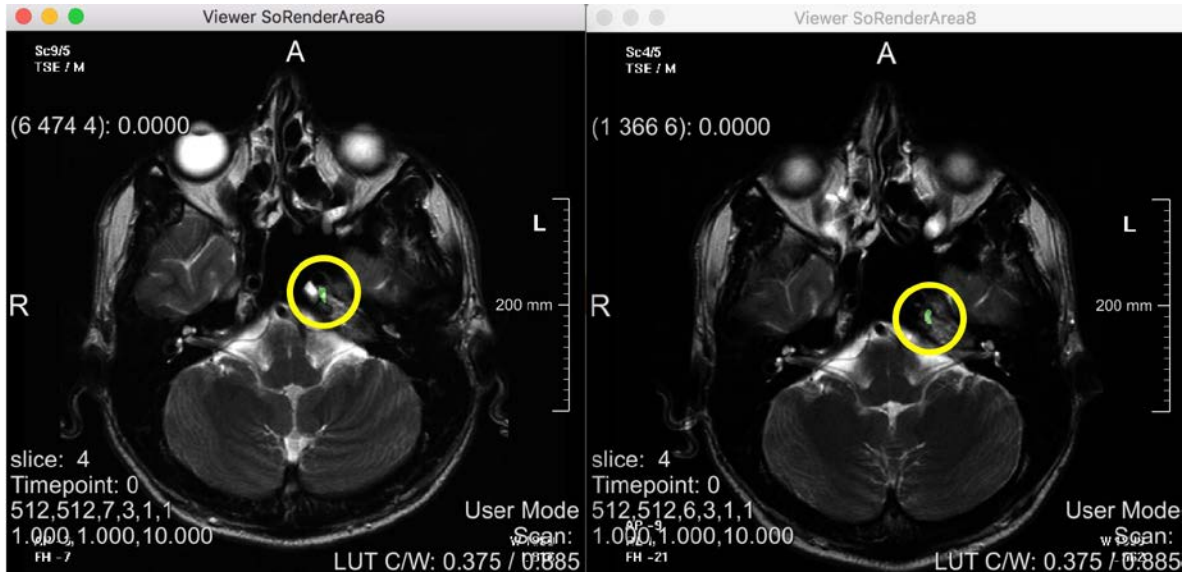


Figure 4-4: Patient2 - 2D slice in different time points (0 and 6 months).

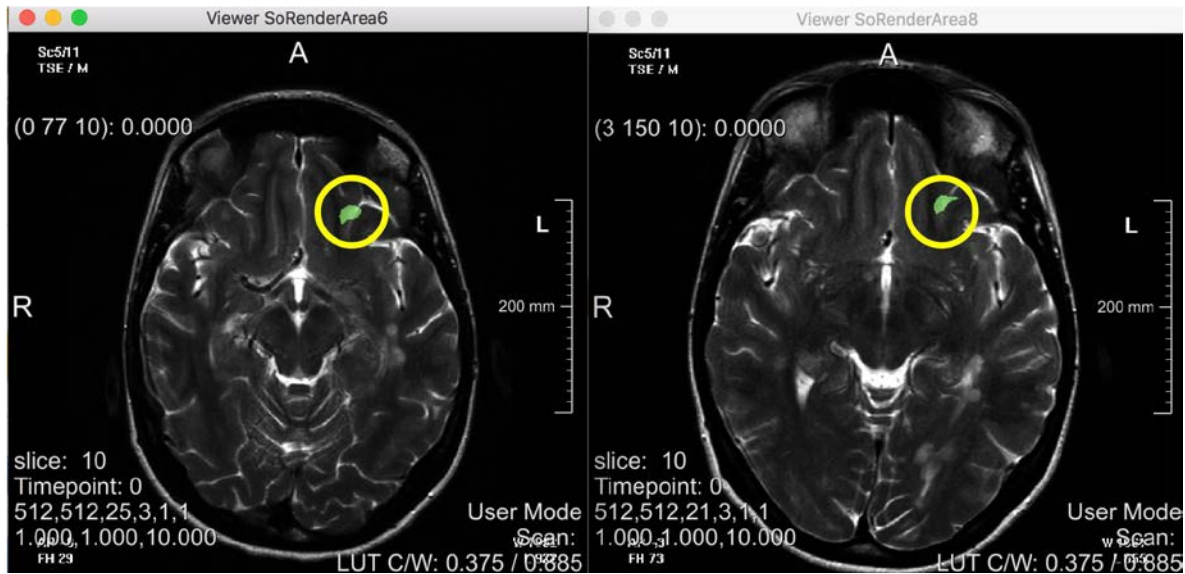


Figure 4-5: Patient3 - 2D slice in different time points (0 and 6 months).

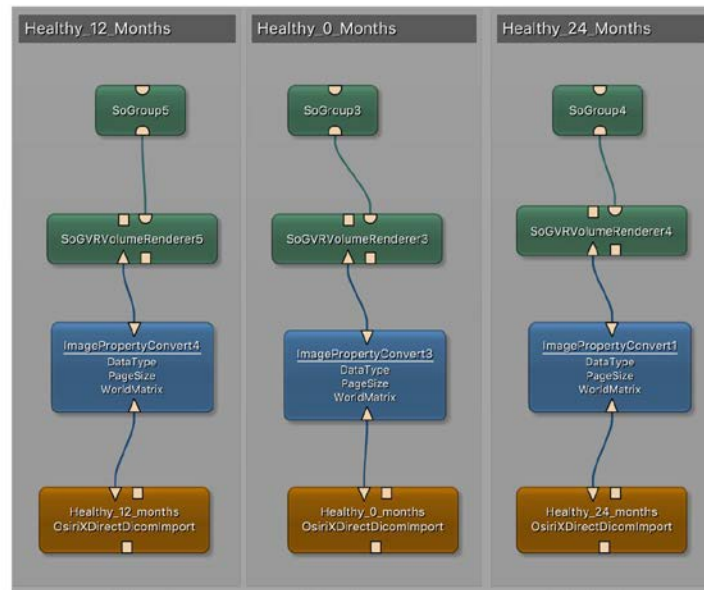
### 4-3 Workflow for 3D-volume reconstruction

Module details that were used for the design of the 3-D workflows are given here below:

- **OsiriXDirectDicomImport - ImagePropertyConvert - ColorModelConvert:** These three type of modules were used as before.
- **SoGVRVolumeRenderer:** The SoGVRVolumeRenderer module allows high-quality 3D-volume Rendering. It is the main rendering module and is complemented with a set of extension modules that allow to customize the rendering. The acronym GVR means Giga Voxel Render [11].
- **SoGroup:** SoGVRVolumeRenderer module includes the information needed to be visualized, while the SoGroup module is the container for this information. Hence the 3D-volume will be visualized inside the SoGroup module [11].

For registering and reconstructing 3-D volumes based on 2-D MRI images in different time points, the workflow depicted in Fig 4-6 was used. The same sub-workflow is used for each time point.

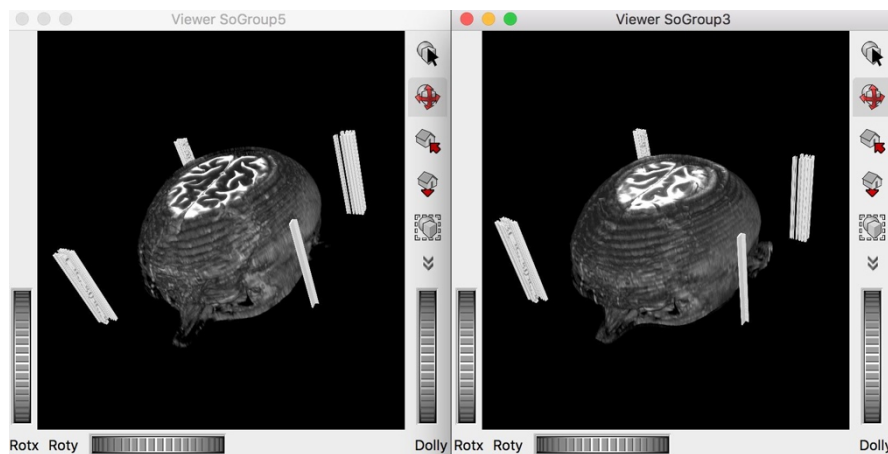




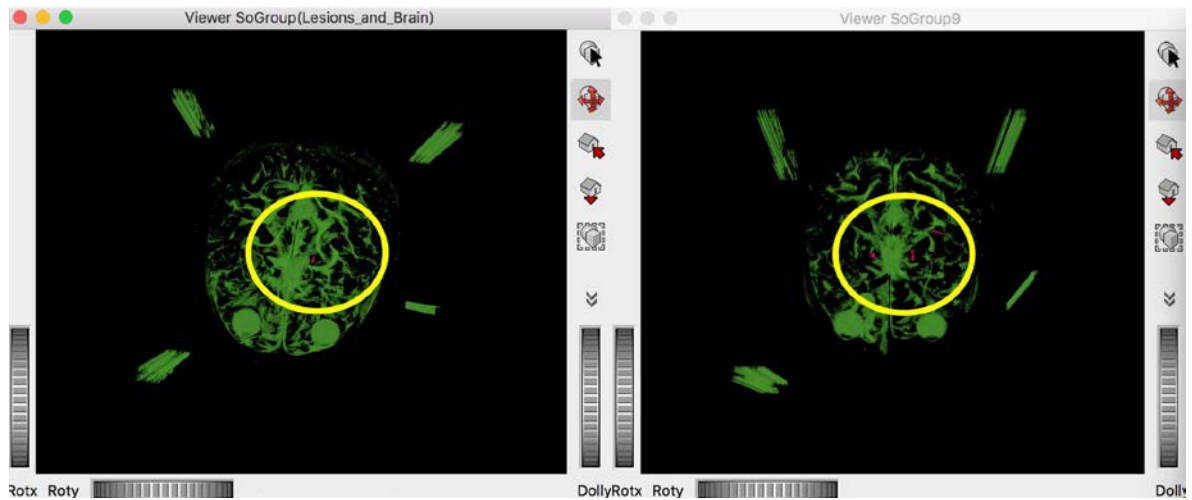
**Figure 4-6:** Workflow for representing 3D MRI volumes at different time points (0, 12 and 24months).

#### 4-4 3D-Scenario

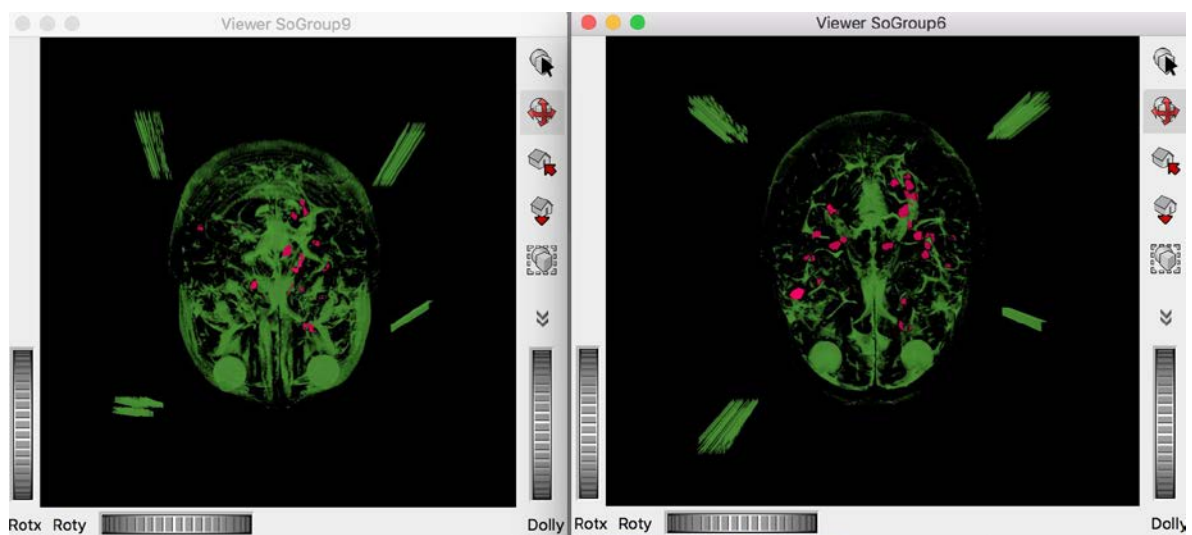
For reconstructing the 3D volume of the brain based on 2D MRI slices, MRI scan from patients with MS and their lesions were manually recorded. Fig 4-7 depicts the 3D-reconstructed volume for a patient at different time points based on the available data, while in figures 4-8 and 4-9 information about the lesions inside the 3D-volumes is visualized. In Fig 4-8 and Fig 4-9 the location and the size of the lesions can be inspected by a specialist.



**Figure 4-7:** Patient1 - 3D volume reconstruction at different time points (0 and 6 months).



**Figure 4-8:** Patient1 - 3D volume reconstruction with lesions at different time points (0 and 6months).



**Figure 4-9:** Patient2 - 3D volume reconstruction with lesions at different time points (0 and 6months).

As can be seen from Fig 4-8 and Fig 4-9 the lesions depicted change over time, showing the progress of the disorder.

---

# Chapter 5

---

## KNIME Workflows

In this chapter two different workflows for KNIME are presented. The first one corresponds to registration of MRI into different time points, while the second depicts the steps for segmenting and labeling the MRI slices a procedure helpful for the identification of the lesions. Moreover, 3D-volume reconstruction was available only using *DICOM* images. A small description of the nodes used to create the workflows is also provided below.

### 5-1 Nodes' Description

A brief summary of the nodes, available in KNIME's and KNIME community's repositories, that were used to construct the segmentation and registration workflows is given below:

#### 1. Registration

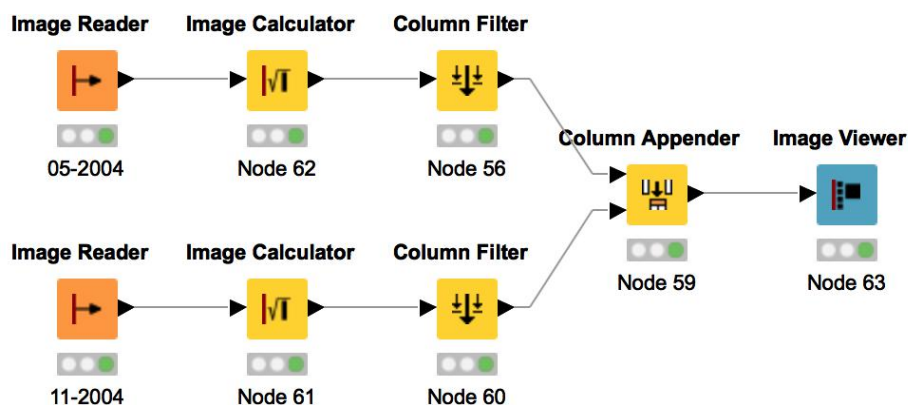
- **Image Reader:** The node is used to import the desired images. The images are imported as a column vector of dimensions  $N \times M$  [12].
- **Image Calculator:** It is used for the evaluation of mathematical expressions based on the imported images. The new results are appended as a new column in the pre-existing image column vector. We used this node to rename my images and create  $n$ -columns for each one of the time points [12].
- **Column Filter:** After appending the new columns, corresponding to each timepoint, the node Column Filter was used in order to discard the initial images [12].
- **Column Appender:** Column appender appends a column vector into a preexisting one. We used this node to concatenate the desired columns and create a matrix [12].
- **Image Viewer:** This node provides a view of the imported image [12].

## 2. Segmentation

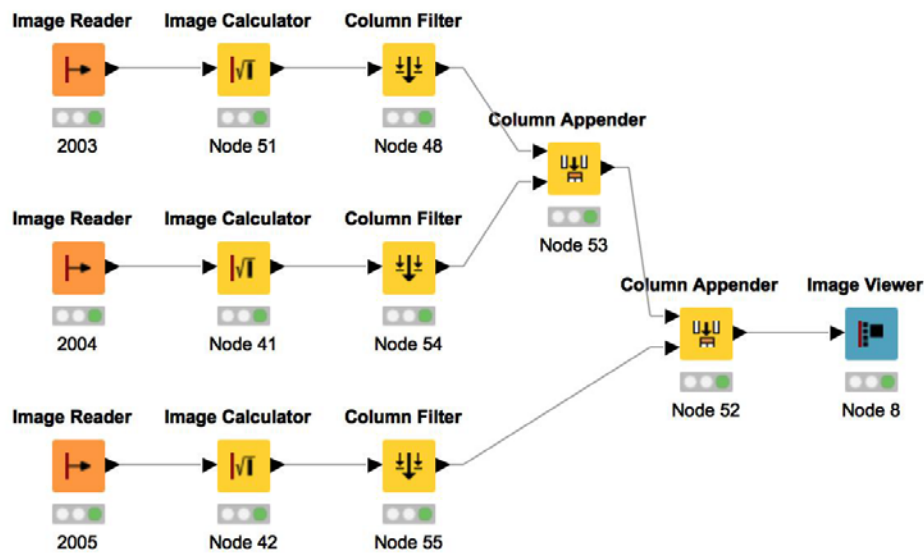
- **Global Threshold:** This node is an algorithm that determines a threshold to distinguish between foreground and background of an image. After the threshold has been computed or manually selected by the user, the algorithm automatically marks any pixel with an intensity value greater than this threshold with "1" and any pixel with intensity lower than the threshold as "0". The result is a binary image which subsequently can be processed with the Connected Component Analysis Node to extract a labeling with separated segments. For this case max entropy was used as a threshold method, meaning that the probability distribution with the largest entropy is the one that best represents the current state of knowledge and this distribution will be applied as a threshold [12].
- **Connected Component Analysis:** It is an algorithm of graph theory that labels the images based on the identification of connected components in binary digital images. This algorithm is often used in computer vision [12].
- **Interactive Segmentation View:** This node allows to view segment labels rendered on top of the original image. You can explore such overlays by adjusting transparency, colors and the used renderer. Filtering of the labels is also possible and allow detailed examination of the segments [12].

## 5-2 Workflow for image registration

The MRI images taken from MS patient were also used for registration at different time points using KNIME. The workflows that were created are depicted in Fig 5-1 and Fig 5-2. The second workflow (see Fig 5-2) is basically an extension of the first in order to incorporate registration in one more time point.

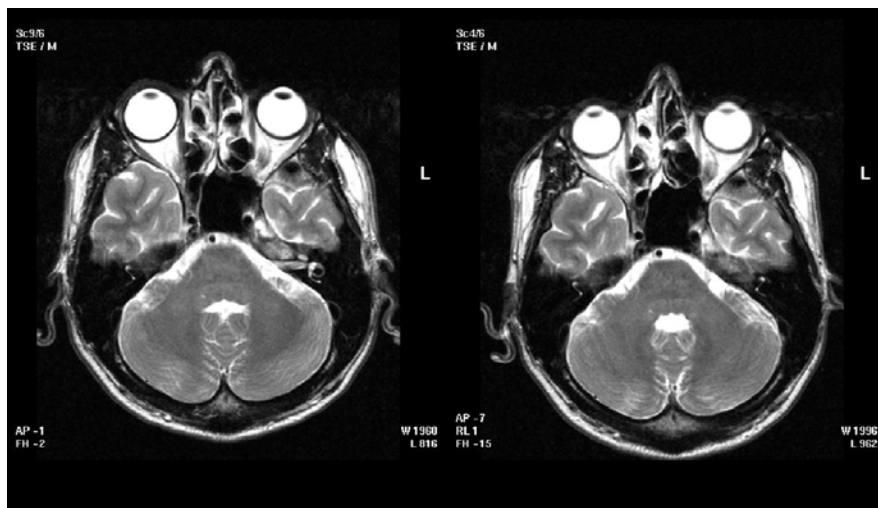


**Figure 5-1:** Workflow for the registration of MRI slices acquired at two different time points (0 and 6 months).

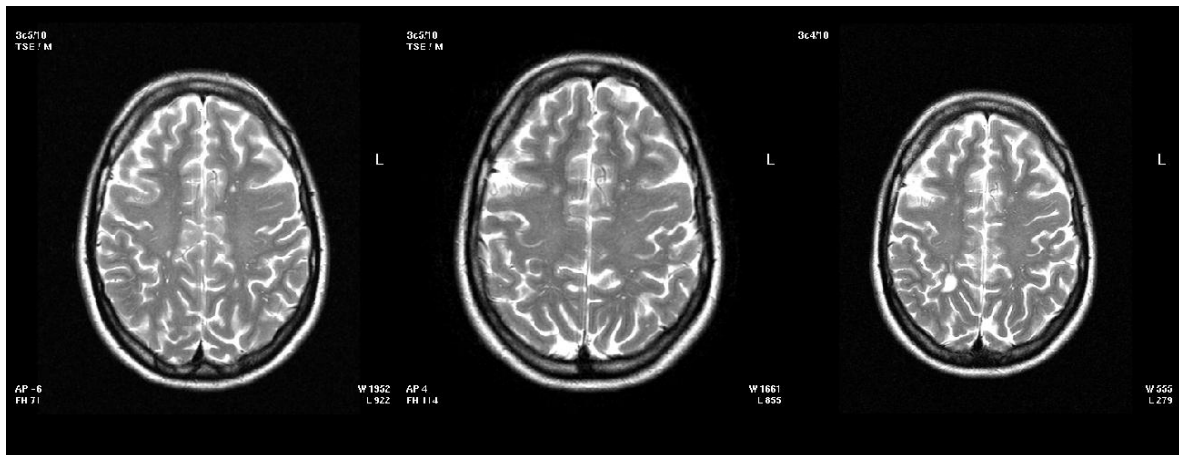


**Figure 5-2:** Workflow for the registration of MRI slices acquired at three different time points(0, 6 and 12 months).

The output of the aforementioned workflow depicts the MRI slices at different time points, allowing as before their visual comparison. The are options like contrast and light adjustment that cab be additionally chosen by the users of the system, which may enhance further the visibility. An example for both workflows is depicted in Fig 5-3 and Fig 5-4 respectively.



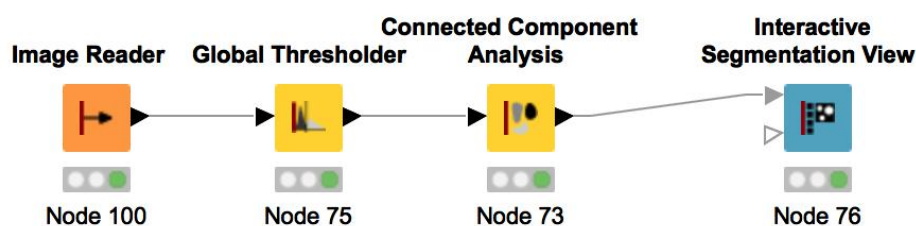
**Figure 5-3:** MRI registration of brain images using KNIME workflows at two different time points(0 and 6 months).



**Figure 5-4:** MRI registration of brain images using KNIME workflows at three different timepoints (0, 6 and 12 months).

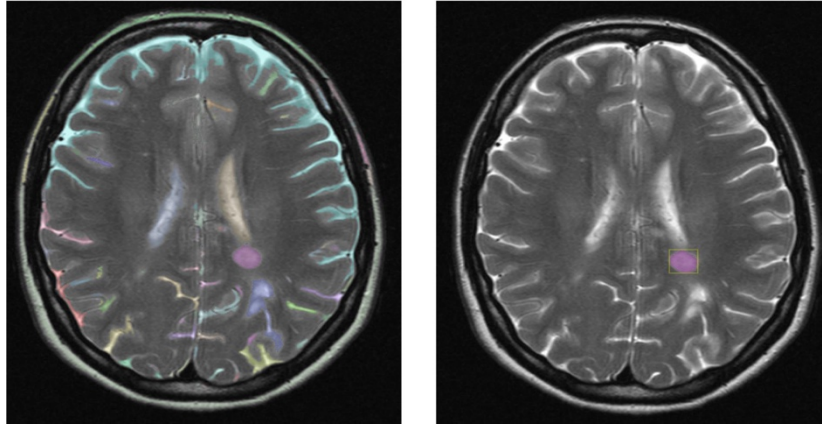
### 5-3 Workflow for image segmentation

Segmentation is a very important process that can help in the identification and visual inspection of MRI lesions. In case of the KNIME workflow, the process of segmentation starts with determining a threshold in order to distinguish between foreground and background image features. The threshold is computed based on an algorithm, such as max entropy. The algorithm creates a new binary image, each pixel of which is represented with a value 0 or 1 based on its previous value. If the pixel's value for the initial image is above that threshold then the same pixel in the new binary image is assigned with 1, otherwise with 0. The new binary image is then used to determine the segments with the same components based on graph theory which are lastly visualized by the software and can be inspected [12]. The segmentation process is depicted in Fig 5-5.

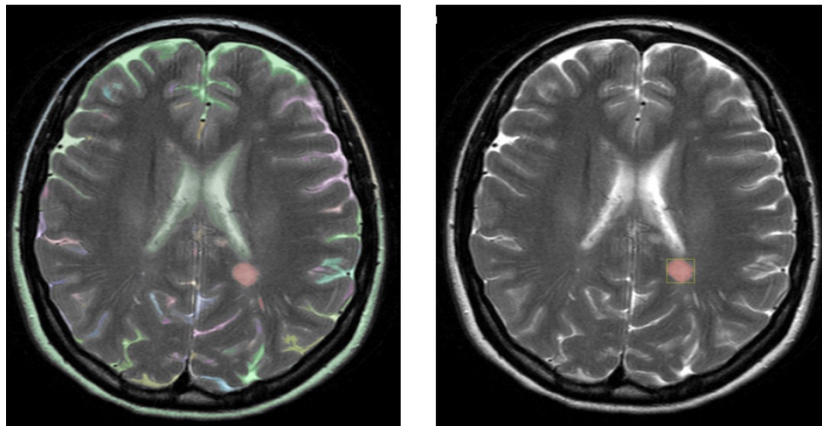


**Figure 5-5:** Segmentation workflow for KNIME depicting three nodes. Image Reader node is used to read the image, Global Thresholder node is used to determine the threshold between foreground and background image features, the Connected Component Analysis node is used to determine the segments with the same components based on the graph theory and the Interactive Segmentation View node is used to visualize the result.

Fig 5-6 and Fig 5-7 represents segmentation of the brain for a patient at two time points (0 and 6 months) with highlighted the point of interest. This helps in visually identifying potential differences.



**Figure 5-6:** MRI segmentation at 1<sup>st</sup> time-point.



**Figure 5-7:** MRI segmentation at 2<sup>nd</sup> time-point.

---

## Chapter 6

---

# MeVisLab-KNIME comparison criteria and an introduction to 3D-Slicer

In this chapter, the comparison criteria between MeVisLab and KNIME are discussed and an introduction to 3D-Slicer was presented.

### 6-1 Overview of MeVisLab and KNIME

Both MeVisLab and KNIME are integrated development environments (IDE) based on visual flow. They consist of a huge variety of simple and more complex modules and nodes that are combined into forming data networks. Inside those networks, images are being processed.

The comparative evaluation of the two systems was based on the following criteria:

- **Color and Opacity Transfer Functions:** These functions render displays in 2D and 3D data with RGBA samples (red, green, blue and alpha). Applications using this functionality include 3D visualization of data with clearly separated structures in terms of data values and location as found in CT of fractures bones [63].
- **Gradient Magnitude Transfer Function Volume Rendering:** These functions enhance regular volume rendering by suppressing samples along a projection ray based on the gradient magnitude at each sample location. This can be used to better show embedded objects like cancer tumors or lesions in a human organ [63].
- **Multidimensional Transfer Function Volume Rendering:** This feature displays a 2D histogram of two arbitrary scalar values that come from the same original volume data. On the histogram, the user can select regions to set opacity and color which then are used by the volume rendering. This functionality can be used to better handle structures with overlapping ranges of data values as present in different regions of a tooth in MRI [63].





- **Tagged Volume Rendering:** It uses different transfer functions and shading effects for each uniquely tagged region in a data set. Hence, different segmented objects can be visualized in various colors and embedded objects can be made opaquer than the enclosing ones. For example, this is useful for the display of organs in human [63].
- **Interactive Segmentation Parameter Finding:** This feature allows displaying on a GUI all relevant segmentation parameter for each supported segmentation filter/algorithm as well as the resulting segmentation output. The user can adjust the parameters and see the corresponding updated segmentation. This is useful when determining the best parameter settings in a segmentation filter when applied to new data sets. An example of using this functionality is when segmenting coronary blood vessels images acquired under varying MRI scanner settings [63].
- **Interactive Prototyping of Research Algorithms:** This functionality combines previously developed algorithm components in new configurations with customized parameter settings. Through visual programming, component inputs, outputs, and parameters can be inspected at any point in the algorithm pipeline. To reduce development time learning curve algorithm components are cast into precompiled modules accessible even for nonprogrammers. A student may use this to study CT scan noise removal methods [63].
- **Analysis of 3D and Time Volume Data:** It imports 4D volume data, processes and visualizes profile curves along time for each 3D position and creates parametric maps. This is the core component of functional MRI analysis of breast tumors to determine if treatment is successful [63].

Based on the aforementioned criteria an effort has been made to implement image segmentation and registration, 3D volume reconstruction, and lesion visualization and measuring. The following comparative table illustrates the functionalities that were possible to be implemented for MeVisLab and KNIME. As can be concluded, none of the two systems could be used to implement the key functionalities.

Functionality	MeVisLab	KNIME
Segmentation	✗	✓
Registration	✓	✓
3D-Volume Reconstruction	✓	✗
Lesion Visualization	✓	✓
Lesion Measurements	✗	✗

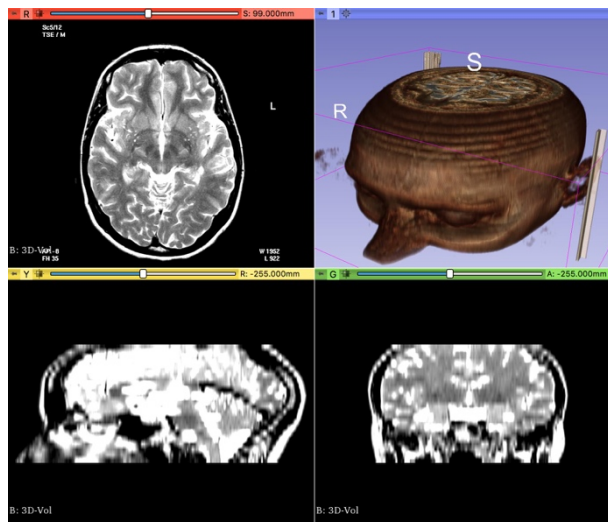
**Table 6-1:** Comparison table of MeVisLab and KNIME illustrating the key functionalities that was possible to be implemented using both of the systems.

## 6-2 3D-Slicer

3D-Slicer was selected to be compared with the aforementioned systems in terms of functionality, as it is one of the most known free software presenting huge capabilities and ease of use for medical imaging research. It provides a highly intuitive graphical user interface, depicting a high variety of available layout for views. The most common one is the one depicting the axial, sagittal, coronal and a 3D view. Moreover, it gives the ability to reconstruct the 3D volume based on 2D images, either in DICOM format or in any other image format. Segmentation and illustration of lesions in different time points is also available. Finally, one of its major advantages is the ability to take lesion measurements with literally one click of the button and depict them inside the specific slice of the 3D volume, providing thus a more holistic representation of the human brain.

Fig 6-1 provides a summary of all available views of 3D-slicer. The axial, sagittal and coronal 2D views can be distinguished, while a 3D view is also available.

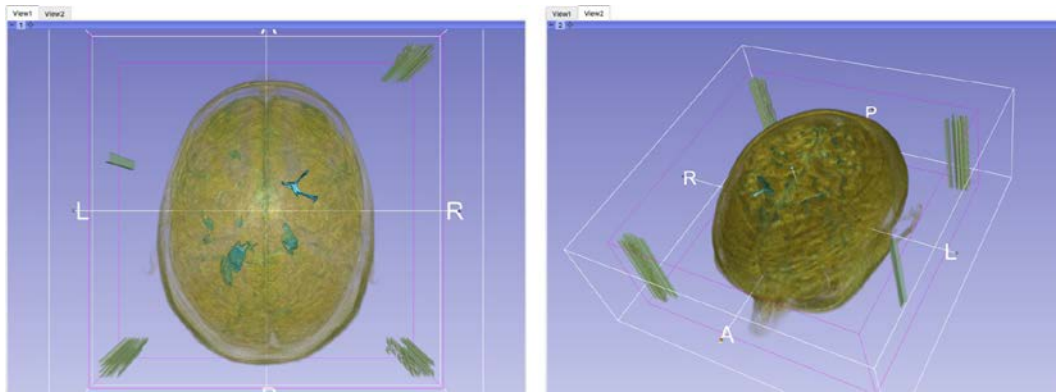
Fig 6-2 depicts two top views of a 3D reconstructed volume. On the left the first available slice is presented, while on the right a randomly selected slice can be seen. In order to achieve this, the region of interest(ROI) changed with simply dragging using the mouse.



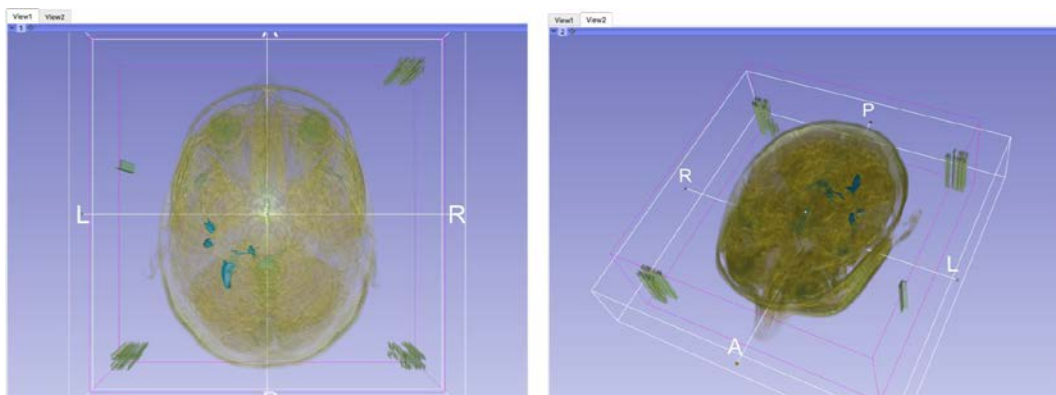
**Figure 6-1:** 3D-Slicer 2D views (axial, sagittal, coronal) and 3D reconstructed view



**Figure 6-2:** 3D-Volume reconstructed. Top and random slice view.

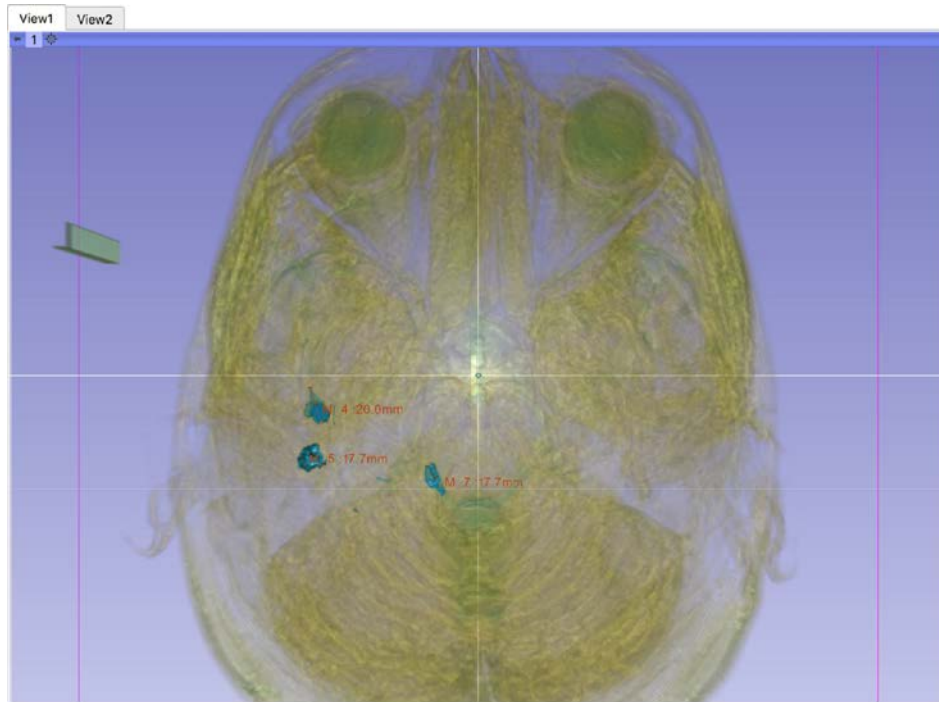


**Figure 6-3:** 3D-Volume reconstruction. Top and side views. Lesions illustration



**Figure 6-4:** 3D-Volume reconstructed. Randomly selected slice view. Lesions illustration

Fig 6-3 and Fig 6-4 represent the same person with lesions in different slices. The modality of the image has changed in order to present lesions in a more distinguishable way. The two figures illustrate the shape of the lesions and their depth in brain. Figure 6-5 presents the dimensions of the selected lesions, providing enriched information about the condition of the patient.



**Figure 6-5:** Measurements of lesions' dimensions of a randomly selected slice.

To finally comprehend how the three systems compare, the following table illustrates that 3D-Slicer outweighs both KNIME and MeVisLab as it can perform all the key functionalities.

Functionality	MeVisLab	KNIME	3D-Slicer
Segmentation	✗	✓	✓
Registration	✓	✓	✓
3D-Volume Reconstruction	✓	✗	✓
Lesion Visualization	✓	✓	✓
Lesion Measurements	✗	✗	✓

**Table 6-2:** Comparison table of MeVisLab, KNIME and 3D-Slicer illustrating the key functionalities that was possible to be implemented using all of the systems.

The following table presents studies that have used KNIME, MeVisLab and 3D-Slicer in medical research. Some of them focused in MS research.

System	Description	Authors
KNIME	Multiple Sclerosis	Herman et al., 2019 [14]
KNIME	Multiple Sclerosis	Mateen, 2018 [15]
KNIME	Medical Research	Dimitriadis et al., 2018 [16]
KNIME	Medical Research	Nicola et al., 2015 [17]
KNIME	Medical Research	Spedding et al., 2015 [18]
KNIME	Medical Research	Sarica et al., 2014 [19]
MeVisLab	Multiple Sclerosis	Egger et al., 2017 [20]
MeVisLab	Multiple Sclerosis	Lutz et al., 2017 [21]
MeVisLab	Multiple Sclerosis	Vollmer et al., 2016 [22]
MeVisLab	Multiple Sclerosis	Mellergård et al., 2012 [23]
MeVisLab	Medical Research	Egger et al., 2017 [24]
MeVisLab	Medical Research	Egger et al., 2017 [25]
MeVisLab	Medical Research	Kohlmann et al., 2016 [26]
MeVisLab	Medical Research	Egger et al., 2014 [27]
MeVisLab	Medical Research	Egger et al., 2012 [28]
MeVisLab	Medical Research	Caban et al., 2007 [29]
3D-Slicer	Multiple Sclerosis	Toschi et al., 2019 [30]
3D-Slicer	Multiple Sclerosis	Plance et al., 2018 [31]
3D-Slicer	Multiple Sclerosis	Tobyne et al., 2018 [32]
3D-Slicer	Multiple Sclerosis	Gouveia et al., 2017 [33]
3D-Slicer	Multiple Sclerosis	Chen et al., 2016 [34]
3D-Slicer	Multiple Sclerosis	Herranz et al., 2016 [35]
3D-Slicer	Medical Research	Kapur et al., 2016 [36]

**Table 6-3:** List of papers about KNIME, MeVisLab and 3D-Slicer, ordered chronologically and alphabetically. The authors used the three aforementioned systems in medical research. Some of them focuses in multiple sclerosis

---

# Chapter 7

---

## Discussion-Conclusions

### 7-1 Discussion

The goal of this project was to identify and evaluate open source medical neuroimaging systems with workflow management features. The main constraints of the selection was to be freely available. Three frameworks were chosen, *MeVisLab*, *KNIME* and *Loni Pipeline*. One of them, *Loni Pipeline*, presented several connectivity issues which has not been solved until recently. Therefore, it was discarded from the study. The rest were examined and evaluated in terms of image registration, image segmentation and 3D volume reconstruction.

The two examined systems provide all the necessary tools to explore and determine data-driven parameter estimates as they have in common data processing techniques (e.g filtering, segmenting, module-wise interface), visualization (e.g 2D cross sections), types of supported input data (e.g DICOM images, TIFF images, etc.) and basic visual interactions (zoom, scroll).

The comparison of the two workflows based on aforementioned criteria showed that both have their own advantages and disadvantages in different areas. Which one is to be chosen depends on the type of application to be written and the type of intended user, however, the information in this review is presented to aid that decision. The different types of example functionalities and applications presented in this paper include tasks that are relevant to image segmentation, image registration and 3D volume reconstruction. A good strategy to determine which framework should be used is to identify the class of applications that one expects to work on the most and then select the framework accordingly.

MeVisLab is the best framework for creating application prototypes, related to biomedical imaging, via visual data flow networks on a computer or for 3D plus time volume data analysis. In contrast, KNIME is the best choice for simulation applications in more than one field. It, as well, uses open source visual data-flow programming. One of the biggest benefits of these systems, i.e those that use visual data-flow programming paradigm is that the user can try out new combinations of algorithms faster than through writing code. In addition, no recompilation or re-execution of algorithm steps unchanged from the previous execution is needed.

KNIME and MeVisLab are similar in this part as they both use this visual data flow paradigm.

KNIME is open source, has a broader feature set with more integrated scientific packages. MeVisLab offers more streamlined automatic analysis of module input/output ports. Both offer scripting capabilities, KNIME more extended as it can integrate most of the programming languages, while only python can be used in MeVisLab. Both frameworks allow the creation of customized end-user applications hiding the data network complexity. To highlight one of the most important benefit achieved from any of the frameworks, consider that they all require less than a day to create a usable application build from pre-existing classes/modules.

Covering their drawbacks, according to my opinion, those systems' major weakness is that they are designed to cover a variety of research. Towards this goal, every functionality is captured in modules or nodes, leading to complex interconnections in case of more high demanding workflows. Therefore, instead of providing flexibility, they achieve exactly the opposite. To that extend, they seem to not suffice for more complex processes related to each specific field. In this case, tailored software is believed to give more functionalities and comfort to the user. By reviewing the functionality of 3D-Slicer, it seems that not only it provides a more intuitive graphical user interface comparing to SWMS, but also the it is consisted of several functions able to perform segmentation, registration, reconstruction and visualization in a more elegant and fast way.

## 7-2 Conclusions

In this section, the conclusions of this project based on the review and the simulations are presented:

1. The two examined systems have common tools to explore and determine data driven parameter estimates.
  - Data processing techniques (e.g filtering).
  - Visualization (e.g 2D cross sections, visual interactions such as zoom and scroll).
  - Supported input data (e.g DICOM images, TIFF images, etc.).
2. MeVisLab is used for biomedical imaging.
3. KNIME is used for simulations in more scientific fields.
4. KNIME and MeVisLab provide modularity allowing departmentalization of the analysis.
5. Users can try new combinations of algorithms faster without the need to write code.
6. No recompilation or re-execution of the unchanged steps from the previous execution is needed.
7. Both offer scripting capabilities (in paid version).
  - Many programming languages can be used with KNIME.



- Only Python can be used with MeVisLab.
8. Both frameworks allow the creation of customized end-user applications in less than a day by using pre-existing classes/modules and therefore hiding the data network complexity.

---

# Bibliography

- [1] H. Lassmann, W. Brück, and C. F. Lucchinetti, "The immunopathology of multiple sclerosis: An overview," in *Brain Pathology*, vol. 17, pp. 210–218, apr 2007.
- [2] M. M. Goldenberg, "Multiple sclerosis review.," *P & T : a peer-reviewed journal forformulary management*, vol. 37, pp. 175–84, mar 2012.
- [3] P. A. Calabresi, "Diagnosis and management of multiple sclerosis," *American FamilyPhysician*, vol. 70, pp. 1935–1944, nov 2004.
- [4] S. L. Hauser, "Multiple sclerosis and other demyelinating diseases," *Harrison's principlesof internal medicine*, vol. 2287, 1994.
- [5] B. G. Weinshenker, "Epidemiology of multiple sclerosis," *Neurologic Clinics*, vol. 14, pp. 291–308, may 1996.
- [6] R. Milo and A. Miller, "Revised diagnostic criteria of multiple sclerosis," *AutoimmunityReviews*, vol. 13, pp. 518–524, apr 2014.
- [7] V. Navikas and H. Link, "Review: Cytokines and the pathogenesis of multiple sclerosis," *Journal of Neuroscience Research*, vol. 45, pp. 322–333, aug 1996.
- [8] M. Kremenchutzky, G. P. Rice, J. Baskerville, D. M. Wingerchuk, and G. C. Ebers, "The natural history of multiple sclerosis: A geographically based study 9: Observations on the progressive phase of the disease," *Brain*, vol. 129, pp. 584–594, mar 2006.
- [9] K. G. Achilleos, C. C. Kannas, C. A. Nicolaou, C. S. Pattichis, and V. J. Promponas, "Open source workflow systems in life sciences informatics," in *IEEE 12th InternationalConference on BioInformatics and BioEngineering, BIBE 2012*, pp. 552–558, IEEE, nov2012.
- [10] "LONI Pipeline at USC."
- [11] "MeVisLab - About MeVisLab."

- [12] “KNIME - About KNIME.”
- [13] C. M. d. C. Santos, C. A. d. M. Pimenta, and M. R. C. Nobre, “The pico strategy for the research question construction and evidence search,” *Revistalatio-americana deenfermagem*, vol. 15, no. 3, pp. 508–511, 2007.
- [14] S. Herman, T. Åkerfeldt, O. Spjuth, J. Burman, and K. Kultima, “Biochemical differences in cerebrospinal fluid between secondary progressive and relapsing–remitting multiple sclerosis,” *Cells*, vol. 8, no. 2, p. 84, 2019.
- [15] A. Mateen, *Knowledge Management approaches to model pathophysiological mechanisms and discover drug targets in Multiple Sclerosis*. PhD thesis, Universitäts- und Landesbibliothek Bonn, 2018.
- [16] S. I. Dimitriadis, D. Liparas, M. N. Tsolaki, A. D. N. Initiative, *et al.*, “Random forest feature selection, fusion and ensemble strategy: Combining multiple morphological mri measures to discriminate among healthy elderly, mci, cmci and alzheimer’s disease patients: From the alzheimer’s disease neuroimaging initiative (adni) database,” *Journal of neuroscience methods*, vol. 302, pp. 14–23, 2018.
- [17] G. Nicola, M. R. Berthold, M. P. Hedrick, and M. K. Gilson, “Connecting proteins with drug-like compounds: Open source drug discovery workflows with bindingdb and knime,” *Database*, vol. 2015, 2015.
- [18] A. L. Spedding, G. Di Fatta, and J. D. Saddy, “An lda and probability-based classifier for the diagnosis of alzheimer’s disease from structural mri,” in *2015 IEEE International Conference on Bioinformatics and Biomedicine (BIBM)*, pp. 1404–1411, IEEE, 2015.
- [19] A. Sarica, G. Di Fatta, G. Smith, M. Cannataro, J. D. Saddy, *et al.*, “Advanced feature selection in multinomial dementia classification from structural mri data,” in *Proc MIC-CAI Workshop Challenge on Computer-Aided Diagnosis of Dementia Based on Structural MRI Data*, pp. 82–91, 2014.
- [20] C. Egger, R. Opfer, C. Wang, T. Kepp, M. P. Sormani, L. Spies, M. Barnett, and S. Schipling, “Mri flair lesion segmentation in multiple sclerosis: Does automated segmentation hold up with manual annotation?,” *NeuroImage: Clinical*, vol. 13, pp. 264–270, 2017.
- [21] T. Lutz, B. Bellenberg, R. Schneider, F. Weiler, O. Köster, and C. Lukas, “Central atrophy early in multiple sclerosis: third ventricle volumetry versus planimetry,” *Journal of Neuroimaging*, vol. 27, no. 3, pp. 348–354, 2017.
- [22] T. Vollmer, L. Huynh, C. Kelley, P. Galebach, J. Signorovitch, A. DiBernardo, and R. Sasane, “Relationship between brain volume loss and cognitive outcomes among patients with multiple sclerosis: a systematic literature review,” *Neurological Sciences*, vol. 37, no. 2, pp. 165–179, 2016.
- [23] J. Mellergård, A. Tisell, O. D. Leinhard, I. Blystad, A.-M. Landtblom, K. Blennow, B. Olsson, C. Dahle, J. Ernerudh, P. Lundberg, *et al.*, “Association between change in normal appearing white matter metabolites and intrathecal inflammation in natalizumab-treated multiple sclerosis,” *PLoS one*, vol. 7, no. 9, p. e44739, 2012.

- [24] J. Egger, M. Gall, A. Tax, M. Ücal, U. Zefferer, X. Li, G. von Campe, U. Schäfer, D. Schmalstieg, and X. Chen, "Interactive reconstructions of cranial 3d implants under mevislab as an alternative to commercial planning software," *PloS one*, vol. 12, no. 3, p. e0172694, 2017.
- [25] J. Egger, M. Gall, J. Wallner, P. Boechat, A. Hann, X. Li, X. Chen, and D. Schmalstieg, "Htcvivevislab integration via openvr for medical applications," *PloS one*, vol. 12, no. 3, p. e0173972, 2017.
- [26] P. Kohlmann, T. Boskamp, A. Köhn, C. Rieder, A. Schenk, F. Link, U. Siems, M. Barann, J.-M. Kuhnigk, D. Demedts, *et al.*, "Remote visualization techniques for medical imaging research and image-guided procedures," in *Visualization in Medicine and Life SciencesIII*, pp. 133–154, Springer, 2016.
- [27] J. Egger, T. Lüddemann, R. Schwarzenberg, B. Freisleben, and C. Nimsky, "Interactive-cut: real-time feedback segmentation for translational research," *Computerized medical imaging and graphics*, vol. 38, no. 4, pp. 285–295, 2014.
- [28] J. Egger, J. Tokuda, L. Chauvin, B. Freisleben, C. Nimsky, T. Kapur, and W. Wells, "Integration of the openigtlink network protocol for image-guided therapy with the medical platform mevislab," *The international Journal of medical Robotics and Computerassisted Surgery*, vol. 8, no. 3, pp. 282–290, 2012.
- [29] J. J. Caban, A. Joshi, and P. Nagy, "Rapid development of medical imaging tools with open-source libraries," *Journal of Digital Imaging*, vol. 20, no. 1, pp. 83–93, 2007.
- [30] N. Toschi, S. De Santis, T. Granberg, R. Ouellette, C. A. Treaba, E. Herranz, and C. Mainero, "Evidence for progressive microstructural damage in early multiple sclerosis by multi-shell diffusion magnetic resonance imaging," *Neuroscience*, 2019.
- [31] V. Planche, I. Koubiyr, J. E. Romero, J. V. Manjon, P. Coupé, M. Deloire, V. Dousset, B. Brochet, A. Ruet, and T. Tourdias, "Regional hippocampal vulnerability in early multiple sclerosis: Dynamic pathological spreading from dentate gyrus to ca 1," *Humanbrain mapping*, vol. 39, no. 4, pp. 1814–1824, 2018.
- [32] S. M. Tobyne, W. B. Ochoa, J. D. Bireley, V. M. Smith, J. J. Geurts, J. D. Schmähmann, and E. C. Klawiter, "Cognitive impairment and the regional distribution of cerebellar lesions in multiple sclerosis," *Multiple Sclerosis Journal*, vol. 24, no. 13, pp. 1687–1695, 2018.
- [33] A. Gouveia, S. Dias, T. Santos, H. Rocha, C. Coelho, L. Ruano, O. Galego, M. Diogo, D. Seixas, M. Sá, *et al.*, "Cognitive impairment and magnetic resonance imaging correlates in primary progressive multiple sclerosis," *Acta NeurologicaScandinavica*, vol. 136, no. 2, pp. 109–115, 2017.
- [34] D. Q. Chen, D. D. DeSouza, D. J. Hayes, K. D. Davis, P. O'Connor, and M. Hodaie, "Diffusivity signatures characterize trigeminal neuralgia associated with multiple sclerosis," *Multiple Sclerosis Journal*, vol. 22, no. 1, pp. 51–63, 2016.
- [35] E. Herranz, C. Gianni, C. Louapre, C. A. Treaba, S. T. Govindarajan, R. Ouellette, M. L. Loggia, J. A. Sloane, N. Madigan, D. Izquierdo-Garcia, *et al.*, "Neuroinflammatory

- component of gray matter pathology in multiple sclerosis," *Annals of neurology*, vol. 80, no. 5, pp. 776–790, 2016.
- [36] T. Kapur, S. Pieper, A. Fedorov, J.-C. Fillion-Robin, M. Halle, L. O'donnell, A. Lasso, T. Ungi, C. Pinter, J. Finet, *et al.*, "Increasing the impact of medical image computing using community-based open-access hackathons: The na-mic and 3d slicer experience," 2016.
- [37] E. Kingwell, J. J. Marriott, N. Jetté, T. Pringsheim, N. Makhani, S. A. Morrow, J. D. Fisk, C. Evans, S. G. Béland, S. Kulaga, J. Dykeman, C. Wolfson, M. W. Koch, and R. A. Marrie, "Incidence and prevalence of multiple sclerosis in Europe: A systematic review," *BMC Neurology*, vol. 13, p. 128, sep 2013.
- [38] P. Browne, D. Chandraratna, C. Angood, H. Tremlett, C. Baker, B. V. Taylor, and A. J. Thompson, "Atlas of multiple sclerosis 2013: A growing global problem with widespread inequity," sep 2014.
- [39] European Multiple Sclerosis Platform, "Multiple sclerosis in Europe," *Online at European Multiple Sclerosis Platform*, p. 29, 2015.
- [40] A. O'Connor, C. Conforti, E. Boyd, R. D. Boer, G. D. Vos, T. Farrell, H. G. Caballero, and M. Stevens, "Multiple sclerosis international federation."
- [41] O. U. o. W. Stüve and J. Oksenberg, *Multiple Sclerosis Overview*. 2010.
- [42] T. Vos, R. M. Barber, and B. Bell, "Global, regional, and national incidence, prevalence, and years lived with disability for 301 acute and chronic diseases and injuries in 188 countries, 1990-2013: A systematic analysis for the Global Burden of Disease Study 2013," *The Lancet*, vol. 386, pp. 743–800, aug 2015.
- [43] P. O'Connor, "Key issues in the diagnosis and treatment of multiple sclerosis An overview," *Neurology*, vol. 59, pp. S1–33, sep 2002.
- [44] D. Miller, F. Barkhof, X. Montalban, A. Thompson, and M. Filippi, "Clinically iso-lated syndromes suggestive of multiple sclerosis, part I: Natural history, pathogenesis, diagnosis, and prognosis," may 2005.
- [45] D. T. Okuda, E. M. Mowry, A. Beheshtian, E. Waubant, S. E. Baranzini, D. S. Goodin, S. L. Hauser, and D. Pelletier, "Incidental MRI anomalies suggestive of multiple sclerosis: The radiologically isolated syndrome," *Neurology*, vol. 72, pp. 800–805, mar 2009.
- [46] F. D. Lublin and S. C. Reingold, "Defining the clinical course of multiple sclerosis: Results of an international survey," apr 1996.
- [47] A. Sadovnick and G. Ebers, "Epidemiology of Multiple Sclerosis: A Critical Overview," *Canadian Journal of Neurological Sciences / Journal Canadien des Sciences Neurologiques*, vol. 20, pp. 17–29, feb 1993.
- [48] G. Kobelt, J. Berg, P. Lindgren, S. Fredrikson, and B. Jönsson, "Costs and quality of life of patients with multiple sclerosis in Europe.," *Journal of neurology, neurosurgery, and psychiatry*, vol. 77, pp. 918–26, aug 2006.

- [49] M. Filippi, M. A. Rocca, O. Ciccarelli, N. De Stefano, N. Evangelou, L. Kappos, A. Rovira, J. Sastre-Garriga, M. Tintorè, J. L. Frederiksen, C. Gasperini, J. Palace, D. S. Reich, B. Banwell, X. Montalban, and F. Barkhof, "MRI criteria for the diagnosis of multiple sclerosis: MAGNIMS consensus guidelines," mar 2016.
- [50] C. H. Polman, S. C. Reingold, B. Banwell, M. Clanet, J. A. Cohen, M. Filippi, K. Fujihara, E. Havrdova, M. Hutchinson, L. Kappos, F. D. Lublin, X. Montalban, P. O'Connor, M. Sandberg-Wollheim, A. J. Thompson, E. Waubant, B. Weinshenker, and J. S. Wolinsky, "Diagnostic criteria for multiple sclerosis: 2010 Revisions to the McDonald criteria," *Annals of Neurology*, vol. 69, pp. 292–302, feb 2011.
- [51] S. Y. Huh, "The early diagnosis and treatments in multiple sclerosis," *Kosin Medical Journal*, vol. 32, p. 151, dec 2017.
- [52] I. Dinov, K. Lozev, P. Petrosyan, Z. Liu, P. Eggert, J. Pierce, A. Zamanyan, S. Chakraborty, J. van Horn, D. S. Parker, R. Magsipoc, K. Leung, B. Gutman, R. Woods, and A. Toga, "Neuroimaging study designs, computational analyses and data provenance using the LONI pipeline," *PLoS ONE*, vol. 5, p. e13070, sep 2010.
- [53] A. W. Toga and P. M. Thompson, "What is where and why it is important," *NeuroImage*, vol. 37, pp. 1045–1049, oct 2007.
- [54] D. B. Keator, J. S. Grethe, D. Marcus, B. Ozyurt, S. Gadde, S. Murphy, S. Pieper, P. D. Greve, R. Notestine, H. J. Bockholt, and P. Papadopoulos, "A national human neuroimaging collaboratory enabled by the biomedical informatics research network (BIRN)," *IEEE Transactions on Information Technology in Biomedicine*, vol. 12, pp. 162–172, mar 2008.
- [55] C. Lin, S. Lu, X. Fei, A. Chebotko, D. Pai, Z. Lai, F. Fotouhi, and J. Hua, "A reference architecture for Scientific workflow management systems and the VIEW SOA solution," *IEEE Transactions on Services Computing*, vol. 2, pp. 79–92, jan 2009.
- [56] A. Tsalgaidou, S. Topouzidou, G. Athanasopoulos, M. Pantazoglou, C. Pautasso, T. Heinis, R. Grønmo, H. Hoff, A.-J. Berre, and M. Glittum, "Developing scientific workflows from heterogeneous services," *ACM SIGMOD Record*, vol. 35, pp. 22–28, jun 2006.
- [57] L. Liu, D. Meier, M. Polgar-Turcsanyi, P. Karkocha, R. Bakshi, and C. R. Guttmann, "Multiple sclerosis medical image analysis and information management," oct 2005.
- [58] D. E. Rex, J. Q. Ma, and A. W. Toga, "The LONI Pipeline Processing Environment," *NeuroImage*, vol. 19, pp. 1033–1048, jul 2003.
- [59] I. D. Dinov, J. D. Van Horn, K. M. Lozev, R. Magsipoc, P. Petrosyan, Z. Liu, A. Mackenzie-Graham, P. Eggert, D. S. Parker, and A. W. Toga, "Efficient, Distributed and Interactive Neuroimaging Data Analysis Using the LONI Pipeline.," *Frontiers in Neuroinformatics*, vol. 3, no. July, p. 22, 2009.
- [60] I. D. Dinov, F. Torri, F. Macchiardi, P. Petrosyan, Z. Liu, A. Zamanyan, P. Eggert, J. Pierce, A. Genco, J. A. Knowles, A. P. Clark, J. D. Van Horn, J. Ames, C. Kesselman, and A. W. Toga, "Applications of the pipeline environment for visual informatics and genomics computations," *BMC Bioinformatics*, vol. 12, p. 304, jul 2011.

- 
- [61] A. MacKenzie-Graham and A. Payan, "Neuroimaging data provenance using the LONI pipeline workflow environment," *Provenance and . . .*, pp. 1–12, 2008.
- [62] B. F. Ritter, T. Boskamp, A. Homeyer, H. Laue, M. Schwier, F. Link, and H.-o. Peitgen, "A Visual Approach," *Direct*, no. November 2011, pp. 60–70, 2011.
- [63] I. Bitter, R. Van Uiter, I. Wolf, L. Ibáñez, and J. M. Kuhnigk, "Comparison of four freely available frameworks for image processing and visualization that use ITK," in *IEEE Transactions on Visualization and Computer Graphics*, vol. 13, pp. 483–493, may2007.
- [64] F. Heckel, M. Schwier, and H.-O. Peitgen, "Object-oriented application development with MeVisLab and Python," *Lecture Notes in Informatics*, vol. 154, pp. 1338–1351, 2009.
- [65] "Getting Started First Steps with MeVisLab," 2018.
- [66] M. R. Berthold, N. Cebron, F. Dill, T. R. Gabriel, T. Kötter, T. Meinl, P. Ohl, K. Thiel, and B. Wiswedel, "KNIME - the Konstanz information miner," *ACM SIGKDDExplorations Newsletter*, vol. 11, no. 1, p. 26, 2009.
- [67] I. Despotović, B. Goossens, and W. Philips, "MRI segmentation of the human brain: Challenges, methods, and applications," 2015.
- [68] T. F. Chan and L. A. Vese, "Active contours without edges," *IEEE Transactions on Image Processing*, vol. 10, no. 2, pp. 266–277, 2001.
- [69] L. Wang, F. Shi, G. Li, Y. Gao, W. Lin, J. H. Gilmore, and D. Shen, "Segmentation of neonatal brain MR images using patch-driven level sets," *NeuroImage*, vol. 84, pp. 141–158, jan 2014.
- [70] D. Terzopoulos, A. Witkin, and M. Kass, "Constraints on deformable models: Recovering 3D shape and nonrigid motion," *Artificial Intelligence*, vol. 36, pp. 91–123, aug 1988.
- [71] J. C. Moreno, V. B. Surya Prasath, H. Proença, and K. Palaniappan, "Fast and globally convex multiphase active contours for brain MRI segmentation," *Computer Vision and Image Understanding*, vol. 125, pp. 237–250, aug 2014.
- [72] J. H. Xue, A. Pizurica, W. Philips, E. Kerre, R. Van De Walle, and I. Lemahieu, "An integrated method of adaptive enhancement for unsupervised segmentation of MRI brain images," *Pattern Recognition Letters*, vol. 24, pp. 2549–2560, nov 2003.
- [73] B. N. Li, C. K. Chui, S. Chang, and S. H. Ong, "Integrating spatial fuzzy clustering with level set methods for automated medical image segmentation," *Computers in Biology and Medicine*, vol. 41, pp. 1–10, jan 2011.
- [74] A. Ortiz, J. M. Gorriz, J. Ramirez, and D. Salas-Gonzalez, "Improving MR brain image segmentation using self-organising maps and entropy-gradient clustering," *Information Sciences*, vol. 262, pp. 117–136, mar 2014.
- [75] B. Fuerst, W. Wein, M. Müller, and N. Navab, "Automatic ultrasound-MRI registration for neurosurgery using the 2D and 3D LC2Metric," *Medical Image Analysis*, vol. 18, pp. 1312–1319, dec 2014.

[76] B. Zitová and J. Flusser, "Image registration methods: A survey," oct 2003.